

W22

Three-Phase Electric Motor

**NEMA
Technical Catalog**

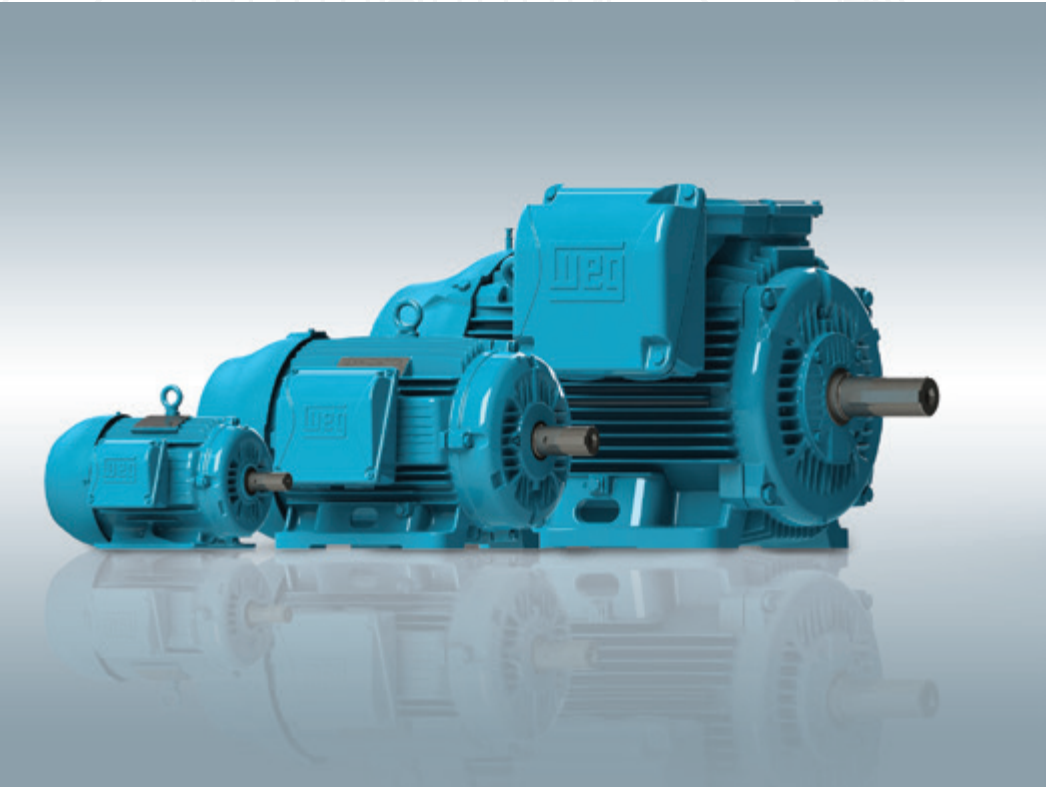



W22 Line

The increasing demand for electrical energy to sustain global development requires consistent heavy investments in power supply generation. However, in addition to complex medium and long term planning, these investments rely on natural resources, which are becoming depleted due to constant pressures upon the environment. The best strategy, therefore, to maintain energy supply in the short term is to avoid wastage and increase energy efficiency. Electric motors play a major role in this strategy, since around 40% of global energy demand is estimated to be related to electric motor applications. Consequently, any initiatives to increase energy efficiency, by using high efficiency electric motors and frequency inverters, are to be welcomed, as they can make a real contribution to reductions in global energy demand.

At the same time as efficiency initiatives make an impact in traditional market sectors, the application of new technologies in emerging sectors is resulting in profound changes in the way that electric motors are applied and controlled. By integrating these changes together with the demands for increased energy efficiency, WEG has taken up the challenge and produced a new design of high efficiency motor, one that exceeds the performance of the previous WEG's W21 motor line, which is recognised worldwide for its quality, reliability and efficiency.

Using the latest generation of computerised tools, such as structural analysis software (finite element analysis) and computer fluid dynamics, as well as electrical design optimization software, an innovative - next generation - product has been developed: the W22 motor.

Several key objectives have been achieved in the design of the W22 motor:

- Reduction of noise and vibration levels;
- Increased energy efficiency and reduced carbon footprint;
- Easy maintenance;
- Compatibility with present & future generations of frequency inverters;
- Flexible and modular design.

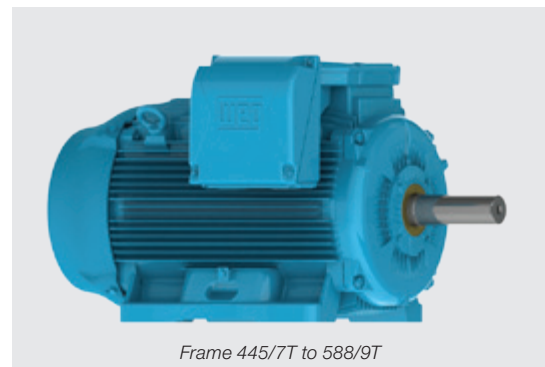
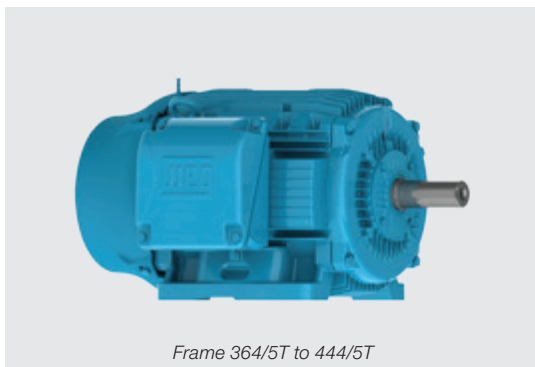

Reducing Carbon Footprint and Cutting Costs with the W22

W22 range of three-phase induction motors, designed to offer not only significantly lower energy consumption, but lower noise and vibration, higher reliability, easier maintenance and lower cost of ownership.

Consisting of three products, each designed to exceed the requirements of the NEMA MG 1-2009, the W22 Super Premium Efficiency, NEMA Premium Efficiency and High Efficiency can reduce energy losses by between 10% and 50% compared with other typical motors. It's an extremely effective way to reduce your carbon footprint, as well as your energy costs.

W22 motors fully comply with the energy efficiency requirements of the EISA 2007 (Energy Independence and Security Act 2007) from USA and EcoAction from Canada.

Visual Index

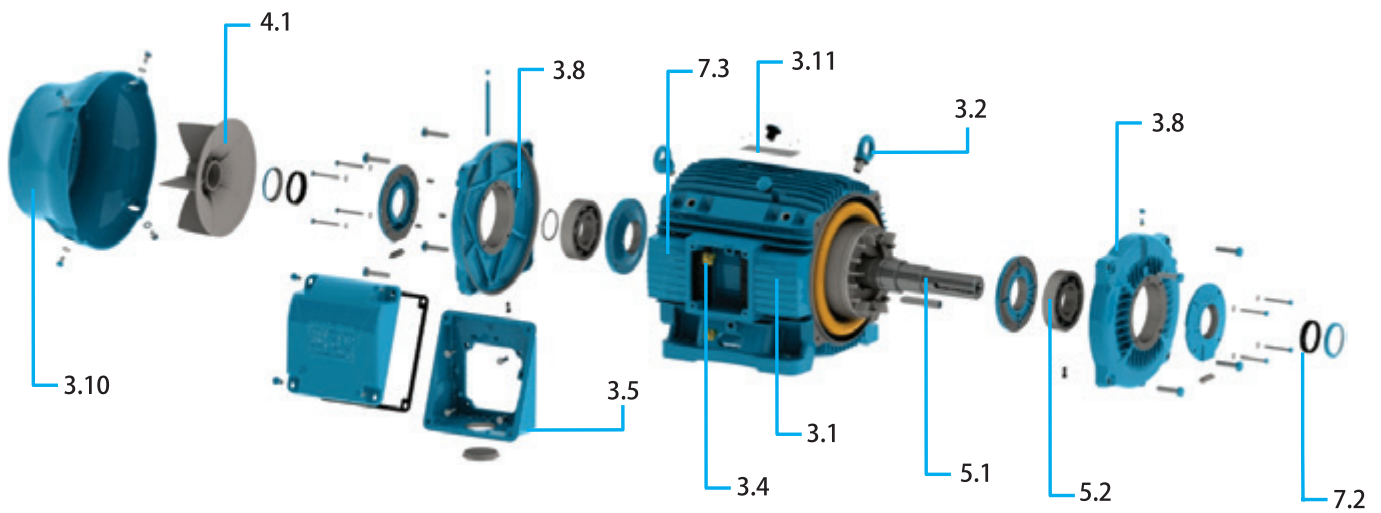

3.1	Frame	Page 6
3.2	Eyebolts	Page 6
3.4	Earth terminals	Page 7
3.5	Terminal box	Page 7
3.8	Endshields	Page 9
3.10	Fan cover	Page 9
3.11	Nameplate	Page 9
4.1	Cooling system	Page 10
5.1	Shaft	Page 11
5.2	Bearings	Page 11
7.2	Sealing system	Page 13
7.3	Painting	Page 13

Table of Contents

1. Versions Available.....	06
2. Standards	06
3. Construction Details.....	06
3.1 Frame.....	06
3.2 Eyebolts.....	06
3.3 Points for Vibration Monitoring.....	06
3.4 Grounding.....	07
3.5 Terminal Box.....	07
3.6 Power Supply Connection Leads.....	08
3.7 Accessory Connection Leads.....	08
3.8 Endshields.....	08
3.9 Drains.....	08
3.10 Fan Cover.....	09
3.11 Nameplate.....	09
4. Cooling System / Noise Level / Vibration Level / Impact Resistance	10
4.1 Cooling System.....	10
4.2 Noise Level.....	10
4.3 Vibration Level.....	10
4.4 Impact Resistance.....	10
5. Shaft / Bearings	11
5.1 Shaft.....	11
5.2 Bearings	11
5.2.1 Permissible Loads.....	11
5.2.2 Bearing Monitoring	13
6. Mounting Forms.....	13
7. Degree of Protection / Sealing System / Painting.....	13
7.1 Degree of Protection	13
7.2 Sealing System.....	13
7.3 Painting	14
7.3.1 Internal Anti-Corrosive Painting	14
8. Voltage / Frequency	14
9. Ambient / Insulation	14
9.1 Space Heaters	15
10. Motor Protections.....	15
10.1 Protection Based on Operating Temperature	15
10.1.1 RTD.....	15
10.1.2 Thermistor (PTC).....	15
10.1.3 Thermostats	15
10.2 Protection Based on Operating Current.....	15
11. Variable Speed Drive Application	16
11.1 Considerations Regarding Voltage Spikes and The Insulation System	16
11.2 Torque Restrictions on Variable Speed Drive Applications.....	16
11.3 Considerations Regarding Bearing Currents	17
11.4 Forced Ventilation Kit.....	17
11.5 Encoders.....	17
12. Construction Features.....	18
13. Optional Features	20
14. Electrical Data	24
15. Mechanical Data	34
16. Terminal Box Drawing.....	37
17. Drip Cover Data	38
18. Distance from Fan Cover to Wall	38
19. Packaging.....	39
19.1 Frames 143T to 215T	39
19.2 Frames 254T to 588/9T	39
20. Spare Parts	40

1. Versions Available

W22 NEMA Motors are available in three versions: W22 High Efficiency, NEMA Premium Efficiency and Super Premium Efficiency. These versions are in accordance with the tables 12-11 and 12-12 from NEMA MG-1.

2. Standards

W22 motors meet the requirements and regulations of the latest version of the following Standards:

CSA C22.2 No. 100-04	Motor and Generators
CSA C390	Test Methods, Marking Requirements and Energy Efficiency Levels for Three-Phase Induction Motors
IEEE STD 112	IEEE Standard Test Procedure for Polyphase Induction Motors and Generators
NEMA MG-1	Motors and Generators
UL 1004-1	Rotating Electrical Machines - General Requirements

Table 1 - Standards

3. Construction Details

The information included in this document refers to standard construction features and the most common variations for W22 motors in low voltage for general applications in frame sizes from 143T to 588/9T.

W22 motors for special and/or customized applications are available on request. For more information, please contact your WEG office or distributor.

3.1 Frame

The W22 frame (figure 1) is manufactured in FC-200 cast iron to provide high levels of mechanical strength to cater for the most critical applications. The cooling fins are designed to minimize the accumulation of liquids and dust over the motor.



Figure 1 - W22 Frame.

The motor feet are completely solid for better mechanical strength (figure 2), allowing easier alignment and installation.

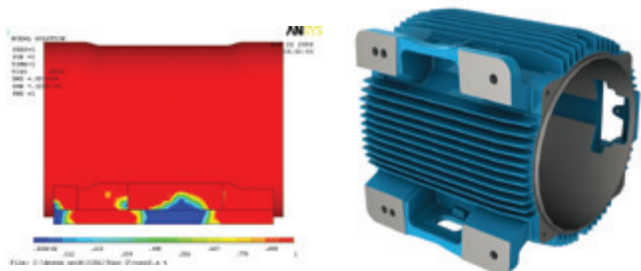

Figure 2 - Solid feet.

3.2 Eyebolts

Eyebolts are available from frame size 182T. The quantity of eyebolts for each frame and mounting is shown in the table 2.

Number of eyebolts	Description
1	Frames 182T to 326T Motors with feet and with side mounted terminal box
2	Frames 182T to 444/5T Motors with feet and with top mounted terminal box
2	Frames 182T to 444/5T - Motors without feet and with C or D flange
2	Frames 445/7T to 588/9T - Motors with feet and side or top mounted terminal box. These motors have four threaded holes in the upper part of the frame for fastening of the eyebolts (figure 3)
2	Frames 445/7T to 588/9T - Motors without feet and with C or D flange. These motors have four threaded holes in the upper part of the frame for fastening of the eyebolts and two more threaded holes in the bottom part

Table 2 - Eyebolts.

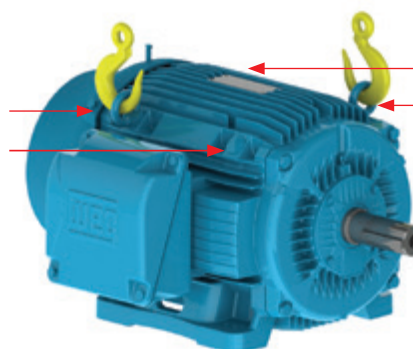

Figure 3 - Motor with four threaded holes for fastening of the eyebolts.

3.3 Points for Vibration Monitoring

To allow easy maintenance, specifically for vibration testing, the 254T to 588/9T frames are designed with flat areas on both ends for better placement of the accelerometer (figure 4). These areas are available both in vertical and horizontal planes. Besides areas on the frame, W22 motors count on flat areas on the endshields for easier installation of accelerometers.

As an option M8 threads for SPM accelerometers can be supplied.

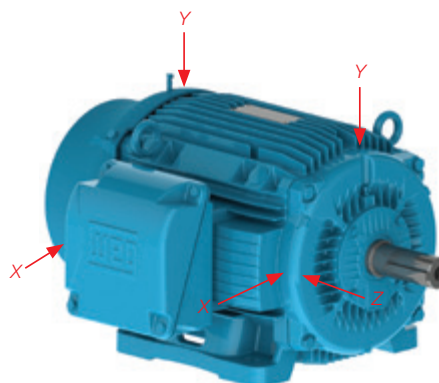

Figure 4 - Flat surfaces for vibration monitoring on the back and front side.

3.4 Grounding

All frames from 143T to 588/9T are provided with earth terminals located inside the terminal box (see figure 5). Motors on frames 364/5T to 588/9T are fitted with one more earth terminal in the frame. It is located at the same side of the terminal box cable outlet (see figure 5) and is responsible to equalize electrical potential and provide greater safety for operators. Capable of withstanding cables from 25 mm² to 185 mm².

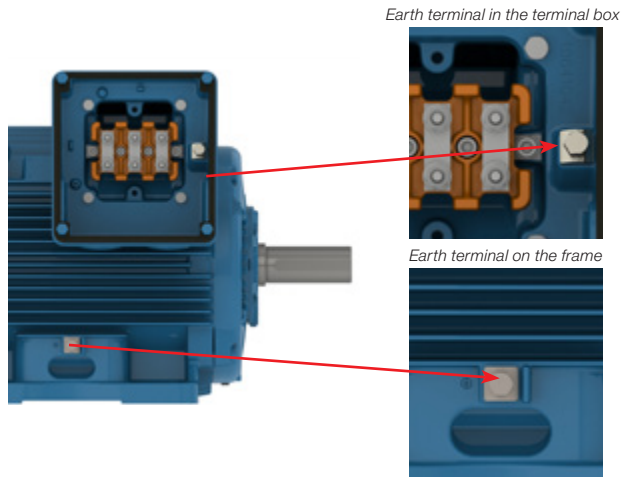

Figure 5 - Earth terminals in the terminal box and on the frame

Optionally, the motors in frames 143T up to 588/9T can be supplied with an additional earth terminal on the opposite side of the frame (see figure 6).

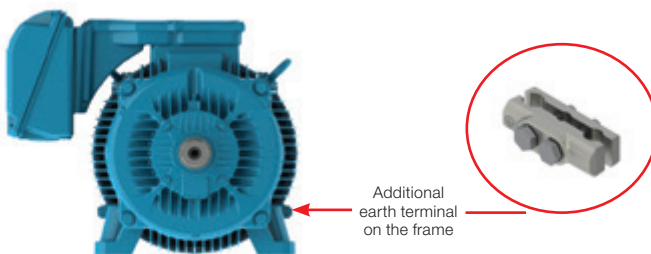

Figure 6 - Additional earth terminal position on the frame.

3.5 Terminal Box

The terminal box of W22 motors is made with FC-200 cast iron, which is the same material used to produce the frame and endshields. It is diagonally split for easier handling of leads and connections.

For frame sizes 445/7T to 588/9T the terminal box is positioned towards the drive end of the motor. This arrangement allows improvement of the airflow over the cooling fins, thus reducing motor operating temperatures. Terminal box position on either the left or right hand side of the motor is possible through the use of an adaptor (see figure 7).

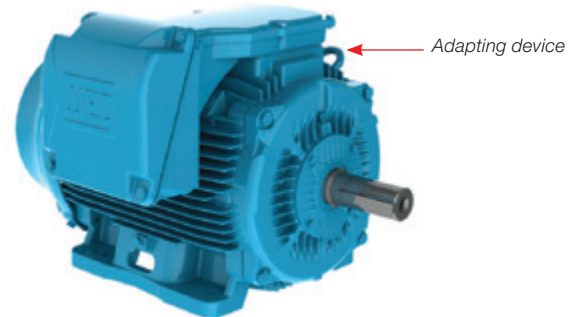

Figure 7 - Terminal box mounted on the left side viewing from shaft drive end side

When supplied from the factory with a side mounted terminal box arrangement, this can be positioned on the opposite side simply by rotating the adaptor.

Similarly, by removing the adaptor and adjusting the length of the motor leads, the terminal box can be positioned on top of the motor.

The flexibility of terminal box positions on the W22 motor offered by the adaptor can be seen in figure 8.



Figure 8 - Terminal box mounted on both sides and on top (versatility).

Conversely, factory supplied motors with the terminal box position on top can be modified to side mounting by fitting the adaptor and extending the motor leads.

For the frame size range 143T to 444/5T the terminal box position is centralized on the motor frame and can be supplied in two configurations - left/ right side (standard) or top (optional) and for changing the mounting (terminal box position), the motor must be disassembled.

Note: for all terminal box position modifications please contact WEG or your local WEG service centre.

For all frames, the terminal box can be rotated in 90° increments. Motors in frame sizes 504/5T, L447/9T, 586/7T and 588/9T are supplied with removable cast iron gland plates.

As an option, the gland plates can be supplied undrilled. Motors are supplied with plastic plugs in the cable entries to maintain the degree of protection during transport and storage.

In order to guarantee the degree of protection, cable entries must comply with at least the same degree of protection indicated on the motor nameplate. Lack of compliance with such detail can invalidate the motor warranty. If required, please contact the WEG Service Area for further advice.

3.6 Power Supply Connection Leads

Motor power supply leads are marked in accordance with NEMA MG-1 Part 2 - Terminal Markings and, as optional, can be fitted with a terminal block made from a polyester based resin BMC (Bulk Molding Compound), duly reinforced with fibre glass (see figure 9).



Figure 9 - Six-pin terminal block.

Motors 588/9T, as optional, can be provided with the terminal block as shown in the figure 10.



Figure 10 - 588/9T terminal block.

3.7 Accessory Connection Leads

Accessory terminals are assembled on connectors whenever the motor is supplied with a terminal block. They may be assembled inside the main power terminal box or in a separate accessory terminal box (figure 11).

Whether the accessory terminals are assembled inside the main power or a separate terminal box, an NPT 3/4" threaded hole is provided for fitting of cable glands for the incoming connection leads.

In the Mechanical Data section of this catalog it is possible to check the quantity of connectors that may be assembled inside the main power and accessory terminal boxes.

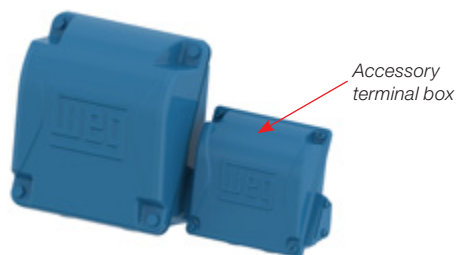

Figure 11 - Accessory terminal box attached to power terminal box.

For frames 213T to 588/9T, there is also the option of providing a dedicated terminal box for the connection of space heaters as shown in figure 12.



Figure 12 - Two accessory terminal boxes attached to power terminal box.

3.8 Endshields

The drive end endshield (figure 13) is designed with fins for better thermal heat dissipation, and to ensure low bearing operating temperatures, resulting in extended lubrication intervals.

For the frames 364/5T to 588/9T, where ventilation is critical for thermal performance of the motor, the endshield fastening screws are placed in such a way so as not to block airflow to any fin, thus contributing to better thermal exchange.

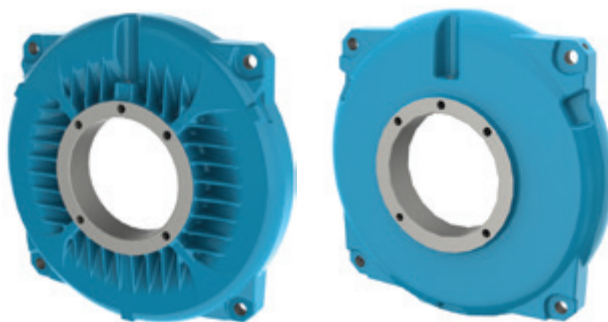

Figure 13 - Drive and non-drive endshields

3.9 Drains

The endshields have holes for drainage of water that may condense inside of the frame. These holes are supplied with rubber drain plugs, in accordance with figure 14. These plugs leave the factory in the closed position and must be opened periodically to allow the exit of condensed water.

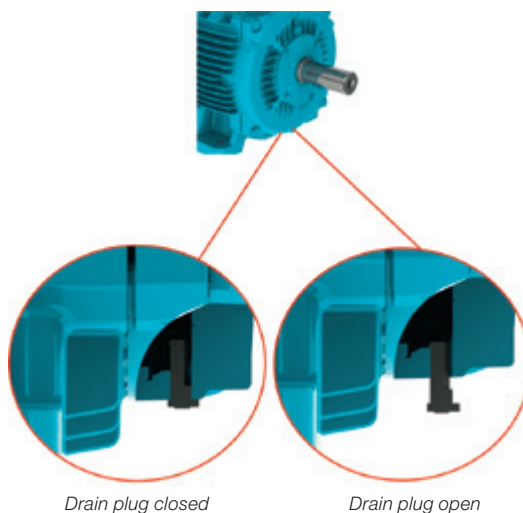

Figure 14 - Detail of the drain plug position on drive endshield

3.10 Fan Cover

The fan cover is made of steel for frames 143T to 215T and FC-200 cast iron for frames 254T to 588/9T. The cast iron fan covers have an aerodynamic design, which results in a significant reduction in noise level and optimized airflow between frame fins for heat exchange improvement. Figure 15 shows the aerodynamic design of the cast iron fan cover.



Figure 15 - Fan cover.

3.11 Nameplate

The nameplate supplies information determining motor construction and performance characteristics. The line name is given on the first line of the nameplate together with nominal efficiency levels as required by NEMA MG-1.



Figure 16 - Nameplate position of W22 motors.



Figure 17 - Nameplate layout for frames 143T to 215T



Figure 18 - Nameplate layout for frames 254T to 588/9T

- 1 - Motor code
- 2 - Three-phase
- 3 - Rated operating voltage
- 4 - Service duty
- 5 - Efficiency
- 6 - Frame size
- 7 - Enclosure
- 8 - Insulation class
- 9 - Temperature rise
- 10 - Design
- 11 - Frequency
- 12 - Motor rated power
- 13 - Full load speed (rpm)
- 14 - Rated operating current
- 15 - Power factor
- 16 - Ambient temperature
- 17 - Service factor

- 18 - Altitude
- 19 - Motor weight
- 20 - Drive end bearing specification and amount of grease
- 21 - Non-drive end bearing specification and amount of grease
- 22 - Type of grease for bearings
- 23 - Connection diagram
- 24 - Relubrication intervals in hours
- 25 - Certification labels*
- 26 - Service factor current
- 27 - NEMA code letters for locked rotor kVA
- 28 - Current at 208 V
- 29 - Model
- 30 - Derating 50 Hz
- 31 - Degree of protection
- 32 - VFD supply

Note: *A CE mark will be available on nameplate if motor frequency shall be 50 Hz or 50/60 Hz.

4. Cooling System / Noise Level / Vibration Level / Impact Resistance

4.1 Cooling System and Noise level

The W22 standard motors are totally enclosed fan cooled (IC411), as per NEMA MG-1 Part 6 (figure 19). Non-ventilated versions (TENV), air over (TEAO) and with forced ventilation TEBC (IC416) are available on request. More information about IC416 option can be found in section 12 - Variable speed drive application.



Figure 19 - Cooling system.

The cooling system (fan, non drive end endshield and fan cover) is designed to minimize the noise level and improve thermal efficiency (figure 20).

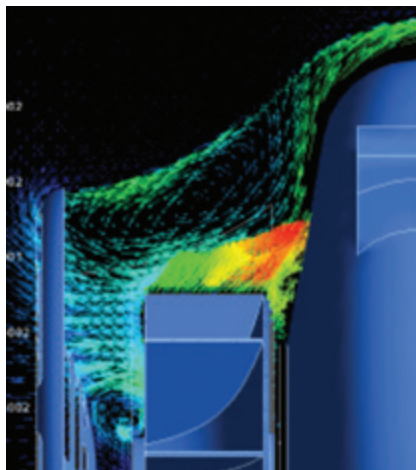

Figure 20 - Cooling system operation

4.2 Noise level

W22 motors comply with NEMA MG-1 Part 9 Standard and the corresponding sound pressure levels. Table 3 shows sound pressure levels in dB(A) which is obtained upon tests at 60 Hz.

Frame	Sound Pressure Level - dB(A)			
	2 Poles	4 Poles	6 Poles	8 Poles
143/5T	68	51	49	47
182/4T	69	58	52	50
213/5T	72	61	55	52
254/6T	72	64	59	54
284/6T	72	64	59	54
324/6T	76/ 74*	68/ 66*	62	56
364/5T	80/ 79*	70/ 67*	64	60
404/5T	80/ 79*	70/ 68*	64	60
444/5T	81	73	69	63
L447/9T	82	79	71	64
504/5T	81	75	70	64
586/7T	84	81/ 78*	77	75
588/9T	89	81	77	75

* Applicable to NEMA Premium Efficiency and Super Premium Efficiency motors
Table 3 - Sound pressure levels for 60 Hz motors.

The noise level values shown in table 3 are taken at no load. Under load the NEMA MG-1 Part 9 foresees an increase of the sound pressure levels as shown in table 4.

Rated Output, HP	2 poles	4 poles	6 poles	8 poles
1.0 < HP ≤ 15	2	5	7	8
15 ≤ HP ≤ 50	2	4	6	7
50 ≤ HP ≤ 150	2	3	5	6
150 ≤ HP ≤ 500	2	3	4	6

Table 4 - Maximum expected increase of sound pressure level for loaded motors.

The global noise level can be reduced up to 2 dB (A) with the installation of a drip cover.

4.3 Vibration Level

Vibration of an electrical machine is closely related to its assembly on the application and, thus, it is generally desirable to perform vibration measurements under installation and operational conditions. Nevertheless, to allow evaluation of the vibration generated by the electrical machine itself in a way to allow reproducibility of the tests and to obtain comparative measurements, it is necessary to perform such measurements with the machine uncoupled, under controlled test conditions. The test conditions and vibration limits described here are those found in NEMA MG-1 Part 7. As an option, motors can be supplied with special vibration levels.

4.4 Impact Resistance

The W22 motor complies with impact level IK08 - mechanical impact of 5J as per EN 62262 - Degrees of protection provided by enclosures for electrical equipment against external mechanical impacts (IK code) ensuring superior mechanical strength for the most demanding applications.

5. Shaft / Bearings

5.1 Shaft

The shaft of W22 standard motors is made of AISI 1040/45 steel, in frames 143T to 364/5T (all polarities), and 404/5T, 444/5T, 445/7T and 504/5T (2 poles) and in AISI 4140 steel for frames 404/5T and up (4 poles) and 447/9T, L447/9T, 586/7T and 588/9T (2 poles). When supplied with roller bearings (optional for frames 213T and above), the shaft material must be AISI 4140.

When fitted with AISI 4140 steel shafts, W22 motors can employ roller bearings, making them suitable for heavy duty applications such as pulley and belt applications. The maximum allowable radial load on shaft ends is in accordance with NEMA MG-1 Part 14 Table 14-1A.

Important: Under such circumstances, the non-drive end bearing cap needs to be replaced as the non-drive end bearing must be locked.

For frames 364/5T and above, the shaft are supplied with a threaded centre hole and have dimensions shown in section 15 - Mechanical Data.

W22 motors can be supplied with a second shaft end on request. As an option, W22 motors can be supplied with stainless steel shafts (AISI 304, AISI 316 and AISI 420) for highly corrosive environments.

Note: 2 pole motors will have as an option only the shaft end in stainless steel AISI 316.

5.2 Bearings

W22 motors are supplied with deep groove ball bearings as standard (figure 21). Optionally, frame size 254T and above can be supplied with NU series roller bearings, where high radial loads may occur.

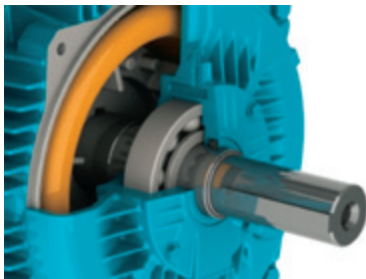

Figure 21 - Bearing view.

The nominal bearing life L10h is 26,280 hours in conformance with maximum radial/axial loads as described in tables 6 and 7. In standard configuration, with ball bearings, the drive end bearing is locked axially from frame 254T. To compensate for any axial movement the motors are fitted with spring washers for frames 143T to 326T and with pre-load springs for frames 364/5T to 588/9T.

When provided with roller bearings, the non-drive end bearing is locked and the axial movement is compensated by the axial play of the front roller bearing.

Bearings lifetime depends on the type and size of the bearing, the radial and axial mechanical loads it is submitted to, operating conditions (environment, temperature), rotational speed and grease life. Therefore, bearing lifetime is closely related to its correct use, maintenance and lubrication.

Respecting the quantity of grease and lubrication intervals allows bearings to reach the lifetime given. W22 motors in frames 254T and above are provided as standard with grease fittings in each endshield to permit the relubrication of the

bearings. The lubrication interval is stamped on nameplate. The lubrication interval is shown in tables 8 and 9, page 12.

It must be emphasized that excessive lubrication, i.e. a quantity of grease greater than that recommended on the motor nameplate, can result in the increase of bearing temperatures leading to reduced operating hours.

Note: L10 lifetime means that at least 90% of the bearings submitted to the maximum indicated loads will reach the number of hours indicated. For bearing lifetime in combined axial and radial loads condition contact WEG.

Important:

1 - Special applications

Motor operation under adverse operating conditions, such as higher ambient temperatures and altitudes or abnormal axial / radial loads, may require specific lubrication measures and alternative lubrication intervals to those indicated in the tables provided within this technical catalog.

2 - Roller bearings

Roller bearings require a minimum radial load to ensure correct operation. They are not recommended for direct coupling arrangements, or for use on 2 pole motors (60 Hz).

3 - Frequency inverter driven motors

Bearing life may be reduced when a motor is driven by a frequency drive at speeds above nominal. Speed itself is one of the factors taken into consideration when determining motor bearing life.

4 - Motors with modified mounting configurations

For motors supplied with horizontal mounting but working vertically, lubrication intervals must be reduced by half.

5.2.1 Permissible Loads

Permissible loads are in accordance with NEMA MG-1 (Table 14-1A), as shown in table 5.

Shaft loading for AC induction horizontal motors with ball bearings Maximum radial overhung load, in pounds, at center of N-W dimension				
Frame sizes	2 poles	4 poles	6 poles	8 poles
143T	106	154	179	192
145T	109	154	176	196
182T	180	227	260	287
184T	180	227	260	289
213T	230	300	350	380
215T	230	300	350	380
254T	470	593	703	774
256T	470	589	705	776
284T	570	735	838	929
286T	570	735	838	929
324T	660	860	990	1100
326T	660	850	980	1090
364T	820	1080	1240	1390
365T	820	1080	1240	1370
404T	-	1270	1450	1600
405T	-	1290	1480	1630
444T	-	1560	1760	1970
445T	-	1520	1760	1970
447T	-	1450	1660	1880
449T	-	1490	1660	1880

Table 5 - Permissible loads for NEMA motors.

- 1 - All belt loads are considered to act in vertically downward direction.
- 2 - Overhung loads include belt tension and weight of sheave.
- 3 - For load at end of the shaft subtract 15%.
- 4 - Radial overhung load limitis based on bearing L-10 life of 26,280 hours.
- 5 - Overhung load limitis do not include any effect of unbalanced magnetic pull.

Radial Loads - Roller bearings

Maximum permissible radial load in pounds - 60 Hz L10 26,280 hours						
Frame	4 poles		6 poles		8 poles	
	(N-W)/2	N-W	(N-W)/2	N-W	(N-W)/2	N-W
254/6T	1435	895	1435	895	1435	895
284/6T	2290	1190	2290	1190	2290	1190
324/6T	2650	1615	2695	1640	2675	1615
364/5T	3280	1840	3300	1865	3325	1885
404/5T	4450	2675	4470	2675	4470	2675
444/5T	5930	3640	6650	3640	6720	3685
445/7T						
447/9T	6515	3255	6065	3030	6450	3235
L447/9T						
504/5T	5460	3210	5485	3235	5485	3235
586/7T	7280	3910	7080	3705	6945	3480
588/9T	6830	3100	6065	2135	6945	3480

Table 6 - Maximum permissible radial load for roller bearings.
Note: the values given for roller bearings take into consideration shaft supplied with steel AISI 4140 (Special order on frames 365T and below).

Axial Loads

Maximum permissible axial load - 60 Hz - 26,280 hours - in pounds							
Frame	Poles	Horizontal		Vertical with shaft upwards		Vertical with shaft downwards	
		Pushing	Pulling	Pushing	Pulling	Pushing	Pulling
143T	2	70	70	70	80	80	70
	4	100	100	90	110	110	90
	6	130	130	120	140	140	120
	8	150	150	140	160	160	140
182/4T	2	130	130	120	150	150	120
	4	180	180	160	210	210	160
	6	230	230	210	270	270	210
	8	280	280	260	310	310	260
213/5T	2	230	230	210	270	270	210
	4	310	310	280	360	360	280
	6	380	380	360	430	430	360
	8	440	440	400	520	520	400
254/6T	2	460	300	420	360	530	260
	4	540	380	480	470	640	330
	6	650	490	600	600	750	430
	8	720	560	650	670	830	490
284/6T	2	610	400	540	510	710	340
	4	730	530	650	650	850	450
	6	850	650	760	810	1010	560
	8	990	790	910	920	1120	710
324/6T	2	650	420	540	600	820	310
	4	800	570	690	760	990	460
	6	960	730	830	940	1170	610
	8	1090	870	970	1070	1300	740
364/5T	2	790	610	620	870	1050	440
	4	1000	820	810	1110	1280	630
	6	1190	1010	980	1350	1530	800
	8	1370	1210	1170	1530	1690	1000
404/5T	2	750	570	550	900	1070	380
	4	1070	890	810	1300	1480	640
	6	1280	1110	1000	1550	1730	830
	8	1440	1260	1150	1750	1930	970
444/5T 445/7T	2	720	550	440	1000	1170	260
	4	1210	1030	830	1660	1840	650
	6	1570	1390	1210	1960	2110	1030
	8	1710	1530	1280	2200	2380	1110
447/9T L447/9T	2	710	540	Under request	1300	1480	Under request
	4	1550	1370	850	2430	2590	670
	6	1870	1690	1210	2740	2920	1030
	8	2160	2000	1480	3030	3210	1330
504/5T	2	640	470	Under request	1080	1260	Under request
	4	1070	890	520	1730	1910	340
	6	1260	1090	660	2090	2270	490
	8	1480	1300	810	2340	2520	640
586/7T 588/9T	2	570	390	Under request	1300	Under request	
	4	1150	980		2430		
	6	1330	1170		2880		
	8	1480	1300		3350		

Table 7 - Maximum permissible axial loads for ball bearings.

Lubrication Intervals (40 °C - Rated Speed)

Lubrication intervals (hours)				
Frame	RPM	Bearing	60 Hz	
143/5	3600	6205	25000	
	1800			
	1200			
	900			
182/4	3600	6207	2500	
	1800			
	1200			
	900			
213/5	3600	6208	23200	
	1800		25000	
	1200			
	900			
254/6T	3600	6309	20,000	
	1800		25,000	
	1200			
	900			
284/6T	3600	6311	14,000	
	1800		25,000	
	1200			
	900			
324/6T	3600	6312	12,000	
	1800		25,000	
	1200			
	900			
364/5T	3600	6314	4000	
	1800		12,000	
	1200			17,000
	900			20,000
404/5T	3600	6316	4000	
	1800		10,000	
	1200			16,000
	900			20,000
444/5T 445/7T	3600	6319	4000	
	1800		8000	
	1200			13,000
	900			17,000
447/9T L447/9T	3600	6322	4000	
	1800		6000	
	1200			11,000
	900			14,000
504/5T	3600	6319	4000	
	1800		8000	
	1200			13,000
	900			17,000
586/7T 588/9T	3600	6322	4000	
	1800		6000	
	1200			11,000
	900			14,000

Table 8 - Lubrication intervals for ball bearings.
Note: the amount of grease is indicated on the nameplate.

Lubrication intervals (hours)				
Frame	RPM	Bearing	60 Hz	
254/6T	3600	NU309	12,000	
	1800		25,000	
	1200			
	900			
284/6T	3600	NU311	8000	
	1800		25,000	
	1200			
	900			
324/6T	3600	NU312	6000	
	1800		21,000	
	1200			
	900			
364/5T	1800	NU314	9000	
	1200		13,000	
	900			19,000
				7000
404/5T	1800	NU316	12,000	
	1200		17,000	
	900			15,000
				4000
444/5T 445/7T	1800	NU319	7000	
	1200		9000	
	900			15,000
				4000
447/9T L447/9T	1800	NU322	7000	
	1200		13,000	
	900			5000
				9000
504/5T	1800	NU319	5000	
	1200		9000	
	900			15,000
				4000
586/7T 588/9T	1800	NU322	4000	
	1200		7000	
	900			13,000
				4000

Table 9 - Lubrication intervals for roller bearings.
Note: the amount of grease is indicated on the nameplate.

5.2.2 Bearing Monitoring

On request, W22 motors can be equipped with bearing temperature detectors which monitor bearing operating conditions. The most commonly used accessory is the RTD temperature detector for continuous monitoring of bearing operating temperature. This type of monitoring is extremely important considering that it directly affects the grease and bearing lives particularly on motors equipped with regreasing facilities.

6. Mounting Forms

Motors are supplied, as standard, in the F-1 configuration, with the terminal box on left hand side of the motor frame when looking from the drive end shaft.



Figure 22 - F-1 mounting.

The mounting configuration for the W22 motor lines comply with NEMA MG-1 Part 4. Standard mounting forms and their variations are shown in table 10.











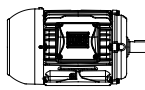
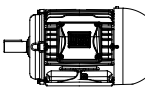
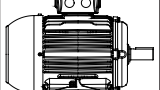

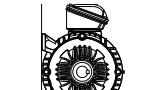
Floor mountings			
Assembly F-1	Assembly F-2	Assembly F-3	
			
Wall mountings			
Assembly W-1	Assembly W-2	Assembly W-3	Assembly W-4
			
Assembly W-5	Assembly W-6	Assembly W-7	Assembly W-8
			
Assembly W-9	Assembly W-10	Assembly W-11	Assembly W-12
			
Ceiling mountings			
Assembly C-1	Assembly C-2	Assembly C-3	
			

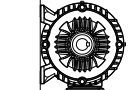
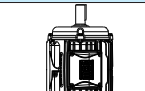
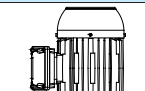
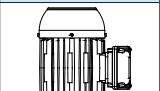
Table 10 - Mountings configurations.

7. Degree of Protection / Sealing System / Painting

7.1 Degree of Protection

As per NEMA MG-1 Part 5, the degree of protection of a rotating electrical machine consists of the letters IP (Ingress Protection), followed by two characteristic numerals, with the following meaning:

- a) First characteristic numeral: referred to protection of people against or approach to live parts and against contacts with moving parts (other than smooth rotating shafts and the like) inside the enclosure and protection of the machine against ingress of solid and foreign objects.
- b) Second characteristic numeral: protection of machines against harmful effects due to ingress of water.

W22 motors are supplied with degrees of protection in conformance with NEMA MG-1 Part 5. As standard, they are IP55, which means:

- a) First characteristic numeral 5: machine protected against dust. The enclosure is protected against contact with moving parts. Ingress of dust is not totally prevented, but dust does not enter in sufficient quantity to interfere with satisfactory operation of the machine.
- b) Second characteristic numeral 5: Machine protected against water jets. Water projected by a nozzle against the machine from any direction shall have no harmful effect.

7.2 Sealing System

The sealing system applied to the shaft of W22 motors in frame 143T to 326T is V-ring. For frames 364/5T to L447/9T the sealing system is the exclusive WSeal®, which consists of a double lipped V-ring with a metallic cap (see figure 23). This configuration operates like a labyrinth preventing ingress of water and dust into the motor.

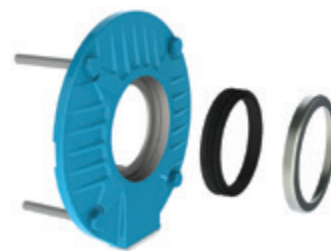

Figure 23 - WSeal®.

For frame sizes 586/7T and 588/9T the sealing system is the Taconite Labyrinth. Alternatively, W22 motors can be supplied with other sealing systems, for example, Oil'seal and the WEG exclusive W3 Seal®, among others (see Section 13 - Optional Features). When fitted with flange, the recommended seal is Lip seal (no contact with liquid) and Oil seal (with contact with liquid).

7.3 Painting



Figure 24 - WEG painting plan

W22 motors of frame 143T to 215T are supplied as standard with WEG internal painting plan 207A.

And, W22 motors of frame 254T up to 588/9T are supplied as standard with WEG internal painting plan 203A.

These painting plans have a minimum resistance to the salt spray test of 240 hours in accordance with ASTM B117-03 and may be used in motors applied in normal environments, slightly severe, sheltered or non-sheltered, for industrial use, with low relative humidity, normal temperature variations and the presence of SO₂.

These painting plans are not recommended for direct exposure to acid steam, alkalis, solvents and salty environments.

Alternative painting plans are suitable to guarantee additional protection in aggressive environments, either protected or unprotected (see section 13 - Optional Features).

Plan	Recommended use
202 E	Severe sheltered industrial environments. May have presence of SO ₂ , vapors, solid contaminants and high relative humidity. Specific use recommendation: for application in pulp and paper, mining and chemical industries.
202 P	Severe industrial environments, sheltered or not, may have the presence of SO ₂ , vapors, solid contaminants and high relative humidity. Specific use recommendations: Indicated for application in food processing motors - USA.
203 A	Regular environments, not too severe, sheltered and non-sheltered, for industrial purpose, with low relative humidity, normal temperature variations and SO ₂ presence. <i>Notes: 1 - Not recommended for direct exposure to acid vapors, alkalis and solvents. 2- Do not apply the 203 plan in motors with steel plate frames.</i>
207 A	Regular environments, not too severe, sheltered or not, for industrial application, with low relative humidity, normal temperature variations and SO ₂ presence. <i>Note: not recommended for direct exposure to acid vapors, alkalis and solvents.</i> Specific use recommendation: for application in motors with steel plate frames, in which packaging process demands quick drying painting.
211 E	Severe industrial environments, sheltered, may have presence of SO ₂ , vapors and solid contaminants, high relative humidity and alkalis and solvent spills. Specific use recommendation: for motors destined to Petrobras and its suppliers, for refineries purposes, as well as petrochemical industries
211 P	Severe industrial environments, sheltered or not, may have presence of SO ₂ , vapors and solid contaminants, high relative humidity and alkalis and solvent spills. Specific use recommendation: specific use recommendation: for motors destined to Petrobras and its suppliers for refineries purposes, as well as petrochemical industries.
212 P	Aggressive marine or industrial marine environments, sheltered and not, high relative humidity may be present. Specific use recommendation: for application in pulp and paper, mining, chemical and petrochemical industries.

Table 11 - Painting plans.

7.3.1 Internal Anti-Corrosive Painting

The integrity of the insulation system is the primary consideration when determining the lifetime of an electric motor. High humidity can result in premature deterioration of the insulation system, therefore for any ambient temperature with relative humidity above 95%, it is recommended to coat all internal components of the motor with an epoxy painting, also known as tropicalization.

8. Voltage / Frequency

NEMA MG-1 Part 12 states that the motor shall operate successfully under running conditions at rated load with a variation in the voltage or the frequency up to the following:

1. Plus or minus 10 percent of rated voltage, with rated frequency.
2. Plus or minus 5 percent of rated frequency, with rated voltage.
3. A combined variation in voltage and frequency of 10 percent (sum of absolute values) of the rated values, provided the frequency variation does not exceed plus or minus 5 percent of rated frequency.

Performance within these voltage and frequency variations will not necessary be in accordance with the standards established for operation at rated voltage and frequency.

9. Ambient / Insulation

Unless otherwise specified, the rated power outputs shown in the electrical data tables within this catalog refer to continuous duty operation S1, as per NEMA MG-1 Part 14 and under the following conditions:

- With ambient temperature range -30°C to +40°C;
- With altitudes up to 3300 feet (1000 meters) above sea level.

For operating temperatures and altitudes differing from those above, the factors indicated in table 12 must be applied to the nominal motor power rating in order to determine the derated available output (P_{max}).

$$P_{max} = P_{nom} \times \text{correction factor}$$

T (°C)	Altitude (m)									
	1000	1500	2000	2500	3000	3500	4000	4500	5000	
10							0.97	0.92	0.88	
15						0.98	0.94	0.90	0.86	
20					1.00	0.95	0.91	0.87	0.83	
25				1.00	0.95	0.93	0.89	0.85	0.81	
30			1.00	0.96	0.92	0.90	0.86	0.82	0.78	
35		1.00	0.95	0.93	0.90	0.88	0.84	0.80	0.75	
40	1.00	0.97	0.94	0.90	0.86	0.82	0.80	0.76	0.71	
45	0.95	0.92	0.90	0.88	0.85	0.81	0.78	0.74	0.69	
50	0.92	0.90	0.87	0.85	0.82	0.80	0.77	0.72	0.67	
55	0.88	0.85	0.83	0.81	0.78	0.76	0.73	0.70	0.65	
60	0.83	0.82	0.80	0.77	0.75	0.73	0.70	0.67	0.62	
65	0.79	0.76	0.74	0.72	0.70	0.68	0.66	0.62	0.58	
70	0.74	0.71	0.69	0.67	0.66	0.64	0.62	0.58	0.53	
75	0.70	0.68	0.66	0.64	0.62	0.60	0.58	0.53	0.49	
80	0.65	0.64	0.62	0.60	0.58	0.56	0.55	0.48	0.44	

Table 12 - Correction factors for altitude and ambient temperature.

Bearing lubrication intervals will change under operating conditions other than 40°C maximum ambient temperature and 1000 meters above sea level. Contact WEG for more information.

All W22 motors are wound with the WISE® insulation system which consists of enamelled conductor wire meeting temperatures up to 200°C and impregnated with solvent free resin. The WISE® system also permits motor operation with variable speed drives (see section 11).

9.1 Space Heaters

The use of space heaters are recommended in two situations:

- Motors installed in environments with relative air humidity up to 95%, in which the motor may remain idle for periods greater than 24 hours;
- Motors installed in environments with relative air humidity greater than 95%, regardless of the operating schedule. It should be highlighted that in this situation it is strongly recommended that an epoxy paint known as internal anti-corrosive painting is applied in the internal components of the motor. More information can be obtained in Section 7.3.

For all frame sizes, W22 motors can be provided with space heaters suitable for 110-127 V, 220-240 V and 380-480 V. Motors in frame sizes 586/7T and 588/9T are supplied with space heaters for 220-240 V as standard. As an option, dual voltage heaters of 110-127 / 220-240 V can be supplied for frame sizes 182T to 588/9T.

The power rating and number of space heaters fitted depends on the size of the motor as indicated in table 13.

Frame	Quantity	Total power rated (W)
143 to 145	1	11
182 to 184	2	22
213 to 256	2	30
284 to 326	2	38
364/5 to 404/5	2	56
444/5 to 504/5	2	140
586/7 to 588/9	2	174

Table 13 - Power and quantity of space heaters.

10. Motor Protections

Protections available for W22 can be classified as follows:

- Based on operating temperature.
- Based on operating current.

In section 12 - Construction Features it is possible to identify the type of protection for each W22 line.

10.1 Protection Based on Operating temperature

Continuous duty motors must be protected from overload either by a device integrated into the motor winding or via an independent protection system, usually a thermal relay with rated or setting current, equal to or below the value obtained when multiplying the power supply rated current (In), as per table 14.

Service Factor	Relay setting current
1.0 up to 1.15	In x S.F.
≥ 1.15	(In x S.F.) - 5%

Table 14 - Relay setting current referred to service factor.

10.1.1 RTD

These are temperature detectors (figure 25) with operating principle based on the properties that some materials vary the electric resistance with the variation in temperature (usually platinum, nickel or copper).



Figure 25 - RTD.

They are also fitted with calibrated resistances that vary linearly with temperature, allowing continuous reading of motor operating temperature through a monitoring display, with high precision rate and response sensitivity. The same detector can serve as alarm (with operation above the regular operating temperature) and trip (usually set up for the maximum temperature of the insulation class).

10.1.2 Thermistor (PTC)

These are thermal protectors consisting of semiconductor detectors with sudden variation of the resistance when reaching a certain temperature (figure 26).



Figure 26 - Thermistor (PTC).

PTC is considered a thermistor with the resistance increasing drastically to a well defined temperature value. This sudden resistance variation blocks the PTC current, causing the output relay to operate, and the main circuit to switch-off. The thermistors are of small dimensions, do not wear and have quicker response if compared to other protectors, although they do not allow continuous monitoring of motor operating temperature.

Together with their electronic circuits, these thermistors provide full protection against overheating caused by overload, under or overvoltage or frequent reversing operations.

Where thermistor protection is required to provide both alarm and trip operation, it is necessary for each phase of the motor winding to be equipped with two sets of appropriately rated thermistors.

WEG Automation has a product called RPW which is an electronic relay intended specifically to read the PTC signal and operate its output relay. For more information go to the website www.weg.net.

10.1.3 Thermostats

These are silver-contact thermal sensors, normally closed, that operate at certain temperature rise. When their operating temperature decreases, they go back to the original position instantaneously, allowing the silver contact to close again.

The thermostats are series-connected with the contactor coil, and can be used either as alarm or trip.

There are also other types of thermal protectors such as Pt-100, KTY and thermocouples. Contact your local WEG office closest to you for more information.

10.2 Protection Based on Operating Current

Overloads are processes that usually make the temperature increase gradually. To solve this problem, the thermal protectors described in item 10.1 are quite suitable. However, the only way to protect motors against short-circuit currents is the application of fuses. This type of protection depends directly on the current and it is highly effective in cases of locked rotor.

WEG Automation supplies fuses in versions D and NH. Go to the site www.weg.net for more information.

11. Variable Speed Drive Application

11.1 Considerations Regarding Voltage Spikes and the Insulation System

The stator windings of W22 motors are wound with class F insulation (class H optional) and are suitable for either DOL starting or via a variable speed drive. They incorporate the WEG exclusive insulation system - WISE® (WEG Insulation System Evolution) - which ensures superior electrical insulation characteristics. The stator winding is suitable for variable speed drive application, taking into account the limits shown in table 15.

Motor rated voltage	Voltage Spikes at motor terminals (phase-phase)	dV/dt * at motor terminals (phase-phase)	Rise time*	Minimum time between successive pulses
$V_{rated} < 460\text{ V}$	$\leq 1600\text{ V}$	$\leq 5200\text{ V}/\mu\text{s}$	$\geq 0.1\ \mu\text{s}$	$\geq 6\ \mu\text{s}$
$460\text{ V} \leq V_{rated} < 575\text{ V}$	$\leq 2000\text{ V}$	$\leq 6500\text{ V}/\mu\text{s}$		
$575\text{ V} \leq V_{rated} \leq 1000\text{ V}$	$\leq 2400\text{ V}$	$\leq 7800\text{ V}/\mu\text{s}$		

Table 15 - Supportability of random wound motors' insulation system
* dV/dt and Rise time definition according to Nema Std. MG1 - Part 30.

Notes:

- If one or more of the above conditions is not attended, a filter (load reactor or dV/dt filter) must be installed in the output of the VSD.
- In order to protect the motor insulation system, the maximum recommended switching frequency is 5 kHz. For information about power cable length see the Technical Guide Induction Motors Fed by PWM Frequency Inverters.
- General purpose motors with rated voltage greater than 575 V, which at the time of purchase did not have any indication of operation with VSD, are able to withstand the electrical limits set in the table above for rated voltage up to 575 V. If such conditions are not fully satisfied, output filters must be used.
- General purpose motors of the dual voltage type, for example 380/660 V, which at the time of purchase did not have any indication of operation with VSD, are able to be driven by a VSD in the higher voltage only if the limits set in the table above for rated voltage up to 460 V are fully attended in the application. Otherwise, a load reactor or a dV/dt filter must be installed in the VSD output.

11.2 Torque Restrictions on Variable Speed Drive Applications

In order to keep the temperature rise of WEG motors within acceptable levels, when under VSD supply, the speed range related loadability limits established in table 16 must be respected.

Note: applications with motors rated for use in hazardous areas must be particularly evaluated - in such case please contact WEG.

TEFC NEMA High Efficiency Motors					
Frame size	Constant torque	Variable torque	Constant power ^(v)	Drive	Comments
143 - 589 ⁽ⁱⁱⁱ⁾	12:1	1000:1	60 - 120 Hz	Any	Constant flux
	100:1 ⁽ⁱⁱ⁾	-	60 - 120 Hz	WEG ⁽ⁱⁱ⁾	Optional flux
589 ^(iv)	4:1	1000:1	60 - 120 Hz	Any	Constant flux
	10:1	-	60 - 120 Hz	WEG ⁽ⁱⁱ⁾	Optional flux
TEFC NEMA Premium Efficiency Motors					
Frame size	Constant torque	Variable torque	Constant power ^(v)	Drive	Comments
143 - 589 ⁽ⁱⁱⁱ⁾	20:1	1000:1	60 - 120 Hz	Any	Constant flux
	1000:1 ⁽ⁱⁱ⁾	-	60 - 120 Hz	WEG ⁽ⁱⁱ⁾	Optional flux
589 ^(iv)	6:1	1000:1	60 - 120 Hz	Any	Constant flux
	12:1	-	60 - 120 Hz	WEG ⁽ⁱⁱ⁾	Optional flux

Table 16 - Loadability limits for W22 motors operating with VSD

- Satisfactory motor performance depends on proper drive setup - please contact WEG
- WEG drive CFW-09 version 2.40 or higher, operating in sensorless (open loop) vector mode
- Motors with rated power $\leq 250\text{ hp}$. Criteria also valid for motors of the frame sizes 447 and 449
- Motors with rated power $> 250\text{ hp}$. Criteria also valid for motors of the frame sizes 447 and 449
- Maximum speeds for safe operation (mechanical issues) must be also observed - refer to Table 16. For CSA certified 2-pole motors, constant horsepower is limited to the range of 60 - 90 Hz.

Notes:

- The speed ranges stated above are related to the motor thermal capability only. Speed regulation will depend on VSD mode of operation and proper adjustment.
- W22 motors of all frame sizes can be blower cooled (independently ventilated) under request. In such case, the motor will be suitable for variable and constant torque applications up to 1000:1 with any drive.

The relations in table 17 correspond to speed ranges of operation. Considering 60 Hz as the base operating frequency, the following equivalence is valid:

Relation	Frequency range
4:1	15 - 60 Hz
10:1	6 - 60 Hz
12:1	5 - 60 Hz
20:1	3 - 60 Hz
100:1	0.6 - 60 Hz
1000:1	0.06 - 60 Hz

Table 17 - Operation range description.

HP	TEFC Motors		
	2 poles	4 poles	6 poles
0.25	7200	3600	2400
0.33			
0.50			
0.75			
1			
1.5			
2			
3			
5			
7.5	5400	2700	
10			
15			
20			
25			
30			
40			
50			
60	4500	2700	1800
75			
100	3600	2250	
125			
150			
200			
250			
300			
350			
400			
450	3600	1800	
500			

Table 18 - Maximum safe operating speeds (rpm) for W22 motors driven by VSD.

Notes:

1. The values in the table are based on mechanical limitations. For operation above nameplate speed, the electrical limitations (motor torque capability) must be also observed.
2. The limits established in table 18 are in accordance with the Nema Std. MG 1 - Part 30.
3. The permissible overspeed value is 10% above the limits given in table 18 (not to exceed 2 minutes in duration) except where the maximum safe operating speed is the same as the synchronous speed at 60 Hz - in such case, please contact WEG.
4. Operation above nameplate speed may require specially refined motor balancing. In such case, vibration and noise limits per Nema MG1 Parts 7 and 9, respectively, are not applicable.
5. Bearing life will be affected by the length of time the motor is operated at various speeds.
6. For speeds and ratings not covered by the table above, please contact WEG.

11.3 Considerations Regarding Bearing Currents

Motors up to frame size 445T generally do not require special features with respect to the bearings for variable speed drive application. From frame size 447T upwards additional measures should be taken in order to avoid detrimental bearing currents. This can be accomplished by means of the use of an insulated bearing or an insulated hub end shield in the non-drive end side and a shaft grounding brush mounted on the drive end shield. Since this is a systems issue, involving the VFD characteristics, Power Cabling and connections issues can occur on smaller motors and the customer experience may dictate these safeguards on much smaller motors.

11.4 Forced Ventilation Kit

For those cases where an independent cooling system is required, the W22 motors can be supplied with a forced ventilation kit, as shown in figure 27.

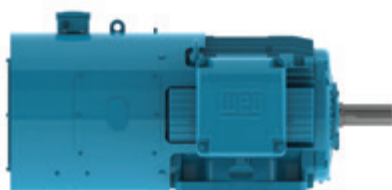

Figure 27 - Forced ventilation kit for W22 motors

When the forced ventilation kit is assembled on the motor in the factory, the overall motor length will be as shown in table 19. As a local stock modification option, an alternative forced ventilation kit can be fitted. Please contact your local WEG office for details of these dimensions.

For more information on VSD motor applications, visit our website (www.weg.net) and download the Technical Guide - Induction Motors Fed by PWM (code 50029350).

Frame	Total motor length (inches)	
	Without forced ventilation	With forced ventilation
143T	12.346	21.952
145T	13.358	22.952
182T	14.860	25.372
184T	15.860	26.372
213T	18.021	28.375
215T	19.517	29.871
254T	23.213	33.331
256T	24.945	35.063
284T	26.433	36.042
284TS	25.061	34.602
284/6T	27.929	37.538
284/6TS	26.557	36.083
286T	27.929	37.538
286TS	26.557	36.102
324T	29.620	39.345
324TS	28.120	37.844
324/6T	31.116	40.840
324/6TS	29.616	39.340
326T	31.116	40.840
326TS	29.616	39.340
364/5T	34.251	45.432
364/5TS	32.338	43.540
404/5T	39.730	49.848
404/5TS	36.732	47.128
444/5T	45.157	55.429
444/5TS	41.407	52.244
445/7T	48.779	59.180
445/7TS	44.951	55.915
447/9T	56.338	67.243
447/9TS	52.588	63.493
L447/9T	57.181	65.630
L447/9TS	53.431	61.882
504/5T	54.095	62.560
504/5TS	48.215	57.238
586/7T	61.902	76.703
586/7TS	55.027	69.828
588/9T	69.381	84.106
588/9TS	62.506	77.175

Table 19 - Forced ventilation dimensions

11.5 Encoders

W22 motors may be supplied with encoders for speed control in closed loop. Encoders can be fitted to motors with either forced ventilation or with shaft mounted cooling fan (TEFC). When encoders are fitted to TEFC machines, motors may not have a second shaft end or be fitted with drip cover. The following models of encoder are available for supply:

- Dynapar - B58N - 1024ppr (hollow shaft)
- Hengstler - RI58 - 1024ppr (hollow shaft)
- Line & Linde - XH861 - 1024ppr (hollow shaft)
- Hubner Berlin - HOG 10 - 1024ppr (hollow shaft)

Other models can be supplied on request.

Note: the encoders described above are of the 1024 pulses per revolution type. As an option, models of 2048 pulses per revolution are available.

12. Construction Features

Frame		143T	145T	182T	184T	213T	215T	254T	256T	284T	286T	
Mechanical features												
Nameplate markings		UL, CSA										
Mounting		F-1										
Frame material		Cast Iron FC-200										
Degree of protection (IP rating)		IP55										
Grounding		Simple grounding - one inside the terminal box										
Cooling method (IC)		Totally enclosed fan-cooled (IC411)										
Fan material	2-4P	Polypropylene										
	6-12P											
Fan cover material		Steel						Cast Iron FC-200				
Endshields material		Cast Iron FC-200										
Drain plug		Fitted with rubber drain plug										
Bearings	Shielded/clearance (DE)	ZZ / Normal						Open / C3				
	Shielded/clearance (NDE)	ZZ / Normal						Open / C3				
	Locating bearing configuration		Without bearing cap and with spring washer at NDE						Locked DE bearing and spring washer at NDE			
	Drive end	2P	6205	6205	6207	6207	6308	6308	6309	6309	6311	6311
		4 - 12P										
Non-drive end	2P	6204	6204	6206	6206	6207	6207	6209	6209	6211	6211	
	4 - 12P											
Bearing seal		V-ring										
Lubrication	Type of grease	Mobil Polyrex EM										
	Grease fitting	None						With grease relief fitting				
Terminal block		None										
Terminal box material		Cast Iron FC-200										
Leads inlet	Main T-box	Size	NPT 3/4"	NPT 3/4"	NPT 1"	NPT 1"	NPT 1"	NPT 1"	NPT 1 1/2"	NPT 1 1/2"	NPT 1 1/2"	NPT 1 1/2"
	Plug		Flat plastic plug for transport and storage									
Shaft	Material	2P	SAE 1040/45									
		4 - 12P										
	DE threaded hole	2P	-	-	-	-	-	-	-	-	-	-
		4 - 12P										
NDE(*) threaded hole	2P	-	-	-	-	-	-	-	-	M12x1.25		
	4 - 12P											
Vibration velocity limit		0.15 in./sec peak										
Nameplate material		Stainless Steel AISI 304										
Painting	Type		207A						203A			
	Color		Blue RAL 5009 - High Efficiency and NEMA Premium Efficiency									
			Green RAL 6002 - Super Premium Efficiency									
Electrical features												
Design	Standard and Super Premium Efficiency		A									
	High and NEMA Premium Efficiency		B									
Voltage		208-230/460 V with 9 leads						208-230/460 V with 12 leads				
Winding	Impregnation		Dip and Bake - Polyester									
	Insulation class		F (DT=80K)									
Service factor		1.25 for High Efficiency and NEMA Premium Efficiency up to 100 HP and for all Super Premium Efficiency motors 1.15 for High Efficiency and NEMA Premium Efficiency of 125 HP and above										
Rotor		Aluminum die cast										
Space heater		None										

(*) NDE Threaded hole is an exclusive feature of NEMA Premium Efficiency and Super Premium Efficiency versions.

Frame		324T	326T	364/5T	404/5T	444/5T	445/7T	447/9T	L447/9T	504/5T	586/7T	588/9T	
Mechanical features													
Nameplate markings		UL, CSA											
Mounting		F-1											
Frame material		Cast Iron FC-200											
Degree of protection (IP rating)		IP55											
Grounding		Simple grounding - one inside the terminal		Double grounding - one inside the terminal box and other one on the frame									
Cooling method (IC)		Totally enclosed fan-cooled (IC411)											
Fan material	2-4P	Polypropylene						2P: Polypropylene 4P: Aluminum	Polypropylene	2P: Polypropylene 4P: Aluminum	Aluminum		
	6-12P	Aluminium											
Fan cover material		Cast Iron FC-200											
Endshields material		Cast Iron FC-200											
Drain plug		Fitted with rubber drain plug											
Bearings		Shielded/clearance (DE)		Open / C3									
		Shielded/clearance (NDE)		Open / C3									
		Locating bearing configuration		Locked DE bearing and spring washer at NDE		Locked on DE with internal and external bearing caps and with preload springs at NDE							
Drive end	2P	6312	6312	6314	6314	6314	6314	6314	6314	6314	6314	6314	
	4 - 12P				6316	6319	6319	6322	6322	6319	6322	6322	
Non-drive end	2P	6212	6212	6314	6314	6314	6314	6314	6314	6314	6314	6314	
	4 - 12P				6314	6316	6319	6319	6316	6319	6316	6319	6319
Bearing seal		V-ring		WSeal®						Taconite Labyrinth			
Lubrication	Type of Grease		Mobil Polyrex EM										
	Grease fitting		With grease relief fitting										
Terminal block		None											
Terminal box material		Cast Iron FC-200											
Leads inlet	Main T-box	Size	NPT 2"	NPT 2"	NPT 3"	NPT 3"	2xNPT 3"	2xNPT 3"	2xNPT 3"	2xNPT 3" (removable gland plate)			
	Plug		Flat plastic plug for transport and storage										
Shaft	Material	2P	SAE 1040/45			SAE 1040/45			SAE 4140	SAE 1040/45	SAE 4140		
		4 - 12P	SAE 4140										
	DE threaded hole	2P	-	-	UNC 3/4"	UNC 3/4"	UNC 3/4"	UNC 3/4"	UNC 3/4"	UNC 3/4"	UNC 3/4"	UNC 3/4"	UNC 3/4"
		4 - 12P	-	-	UNC 3/4"	UNC 3/4"	UNC 3/4"	UNC 3/4"	UNC 3/4"	UNC 3/4"	UNC 3/4"	UNC 7/8"	UNC 7/8"
NDE(*) threaded hole	2P	M12x1.25			M20x2.5								
	4 - 12P	M20x2.5											
Vibration velocity limit		0.15 in./sec peak											
Nameplate material		Stainless Steel AISI 304											
Painting	Type		203A										
	Color		Blue RAL 5009 - High Efficiency and NEMA Premium Efficiency Green RAL 6002 - Super Premium Efficiency										
Electrical features													
Design	Standard and Super Premium Efficiency		A										
	High and NEMA Premium Efficiency		B										
Voltage		208-230/460 V (12 leads)										460 V (6 leads)	
Winding	Impregnation		Dip and bake - Polyester		Continuous resin flow - Polyester								
	Insulation class		F (DT=80K)										
Service factor		1.25 for High Efficiency and NEMA Premium Efficiency up to 100 HP and for all Super Premium Efficiency motors 1.15 for High Efficiency and NEMA Premium Efficiency of 125 HP and above										1.00	
Rotor		Aluminum die cast											
Space heater		None										200-240 Vac	

13. Optional Features

Frame	143T	145T	182T	184T	213T	215T	254T	256T	284T	286T
Terminal box										
Accessory terminal box	0	0	0	0	0	0	0	0	0	0
Terminal box with removable base	NA	NA	NA	NA	NA	NA	NA	NA	NA	NA
Gland plate	0	0	0	0	0	0	0	0	0	0
Epoxy compound on leads entry	0	0	0	0	0	0	0	0	0	0
Self-extinguishing foam at leads entry	S	S	S	S	S	S	S	S	S	S
Terminal block										
BMC terminal block - six pin	0	0	0	0	0	0	0	0	0	0
BMC terminal block - twelve pin	0	0	0	0	0	0	0	0	0	0
HGF connection terminal	NA	NA	NA	NA	NA	NA	NA	NA	NA	NA
Cable glands										
Plastic cable gland	0	0	0	0	0	0	0	0	0	0
Brass cable gland	0	0	0	0	0	0	0	0	0	0
Stainless Steel cable gland	0	0	0	0	0	0	0	0	0	0
Flange										
Flange D	0	0	0	0	0	0	0	0	0	0
Flange C	0	0	0	0	0	0	0	0	0	0
Fan										
Polypropylene (2 poles)	S	S	S	S	S	S	S	S	S	S
Polypropylene (from 4 poles on)	S	S	S	S	S	S	S	S	S	S
Conductive Plastic (2 poles)	0	0	0	0	0	0	0	0	0	0
Conductive Plastic (from 4 poles on)	0	0	0	0	0	0	0	0	0	0
Aluminum (2 poles)	0	0	0	0	0	0	0	0	0	0
Aluminum (from 4 poles on)	0	0	0	0	0	0	0	0	0	0
Cast iron	0	0	0	0	0	0	0	0	0	0
Bronze	0	0	0	0	0	0	0	0	0	0
Fan cover										
Steel plate	S	S	S	S	S	S	0	0	0	0
Cast iron	0	0	0	0	0	0	S	S	S	S
Bearing										
Roller bearing (DE)	NA	NA	NA	NA	0	0	0	0	0	0
Insulated drive end bearing	NA	NA	NA	NA	NA	NA	NA	NA	NA	NA
Insulated non drive end bearing	NA	NA	NA	NA	NA	NA	NA	NA	NA	NA
Bearing cap										
Without bearing cap	S	S	S	S	S	S	NA	NA	NA	NA
With bearing cap	0	0	0	0	0	0	S	S	S	S
Bearing sealing										
Nitrillic rubber lip seal	0	0	0	0	0	0	0	0	0	0
Nitrillic rubber oil seal	0	0	0	0	0	0	0	0	0	0
Viton lip seal	0	0	0	0	0	0	0	0	0	0
Viton oil seal	0	0	0	0	0	0	0	0	0	0
Viton oil seal with stainless steel spring	0	0	0	0	0	0	0	0	0	0
Taconite labyrinth	0	0	0	0	0	0	0	0	0	0
W3 Seal®	0	0	0	0	0	0	0	0	0	0
Shaft										
Second shaft end	0	0	0	0	0	0	0	0	0	0
TS shaft end (from 4 poles on)	NA	NA	NA	NA	NA	NA	NA	NA	0	0
Threaded center hole	0	0	0	0	0	0	0	0	0	0
Locking shaft device (standard for roller bearing motors)	NA	NA	NA	NA	0	0	0	0	0	0
Lubrication										
Aeroshell 7 / Aeroshell 22	0	0	0	0	0	0	0	0	0	0
Isoplex NBU 15	0	0	0	0	0	0	0	0	0	0
Krytox	0	0	0	0	0	0	0	0	0	0
Grease nipple										
Carbon steel grease nipple	0	0	0	0	0	0	S	S	S	S
Stainless steel grease nipple	0	0	0	0	0	0	0	0	0	0

Notes: 1) Other optional features, on request.

2) Some combinations of optional features are not allowed - then contact WEG.

S (Standard)

NA (Not available)

0 (Optional)

Frame	324T	326T	364/5T	404/5T	444/5T	445/7T	447/9T	L447/9T	504/5T	586/7T	588/9T
Terminal box											
Accessory terminal box	0	0	0	0	0	0	0	0	0	0	0
Terminal box with removable base	NA	NA	0	0	0	0	0	S	0	S	S
Gland plate	0	0	0	0	0	0	0	0	0	0	0
Epoxy compound on leads entry	0	0	0	0	0	0	0	0	0	0	0
Self-extinguishing foam at leads entry	S	S	S	S	S	S	S	S	S	S	S
Terminal block											
BMC terminal block - six pin	0	0	0	0	0	0	0	0	0	0	NA
BMC terminal block - twelve pin	0	0	0	0	0	0	0	0	0	0	NA
HGF connection terminal	NA	NA	NA	NA	NA	NA	NA	NA	NA	NA	0
Cable glands											
Plastic cable gland	0	0	0	0	0	0	0	0	0	0	0
Brass cable gland	0	0	0	0	0	0	0	0	0	0	0
Stainless Steel cable gland	0	0	0	0	0	0	0	0	0	0	0
Flange											
Flange D	0	0	0	0	0	0	0	0	0	0	0
Flange C	0	0	0	0	0	0	0	0	0	0	0
Fan											
Polypropylene (2 poles)	S	S	S	S	S	S	S	S	S	S	NA
Polypropylene (from 4 poles on)	S	S	S	S	S	S	NA	NA	S	NA	NA
Conductive Plastic (2 poles)	0	0	0	0	0	0	0	0	0	NA	NA
Conductive Plastic (from 4 poles on)	0	0	0	0	0	0	NA	NA	0	NA	NA
Aluminum (2 poles)	0	0	0	0	0	0	0	0	0	0	S
Aluminum (from 4 poles on)	0	0	0	0	0	0	S	S	0	S	S
Cast iron	0	0	0	0	0	0	0	0	0	0	0
Bronze	0	0	0	0	0	0	0	0	0	0	0
Fan cover											
Steel plate	0	0	0	0	0	0	0	0	0	0	0
Cast iron	S	S	S	S	S	S	S	S	S	S	S
Bearing											
Roller bearing (DE)	0	0	0	0	0	0	0	0	0	0	0
Insulated drive end bearing	NA	NA	0	0	0	0	0	0	0	0	0
Insulated non drive end bearing	NA	NA	0	0	0	0	0	0	0	0	0
Bearing cap											
Without bearing cap	NA	NA	NA	NA	NA	NA	NA	NA	NA	NA	NA
With bearing cap	S	S	S	S	S	S	S	S	S	S	S
Bearing sealing											
Nitrilic rubber lip seal	0	0	0	0	0	0	0	NA	NA	NA	NA
Nitrilic rubber oil seal	0	0	0	0	0	0	0	NA	NA	NA	NA
Viton lip seal	0	0	0	0	0	0	0	0	0	0	0
Viton oil seal	0	0	0	0	0	0	0	0	0	0	0
Viton oil seal with stainless steel spring	0	0	0	0	0	0	0	0	0	0	0
Taconite labyrinth	0	0	0	0	0	0	0	0	0	S	S
W3 Seal®	0	0	0	0	0	0	0	0	0	0	0
Shaft											
Second shaft end	0	0	0	0	0	0	0	0	0	0	0
TS shaft end (from 4 poles on)	0	0	0	0	0	0	0	0	0	0	0
Threaded center hole	0	0	S	S	S	S	S	S	S	S	S
Locking shaft device (standard for roller bearing motors)	0	0	0	0	0	0	0	0	0	0	0
Lubrication											
Aeroshell 7 / Aeroshell 22	0	0	0	0	0	0	0	0	0	0	0
Isoflex NBU 15	0	0	0	0	0	0	0	0	0	0	0
Krytox	0	0	0	0	0	0	0	0	0	0	0
Grease nipple											
Carbon steel grease nipple	S	S	S	S	S	S	S	S	S	S	S
Stainless steel grease nipple	0	0	0	0	0	0	0	0	0	0	0

Frame	143T	145T	182T	184T	213T	215T	254T	256T	284T	286T
Drain										
Rubber drain plug	S	S	S	S	S	S	S	S	S	S
Threaded drain plug	0	0	0	0	0	0	0	0	0	0
Stainless steel threaded drain plug (closed)	0	0	0	0	0	0	0	0	0	0
T-type drain plug (opened)	0	0	0	0	0	0	0	0	0	0
Degree of protection										
IP56	0	0	0	0	0	0	0	0	0	0
IP65	0	0	0	0	0	0	0	0	0	0
IP66	0	0	0	0	0	0	0	0	0	0
IPW55	0	0	0	0	0	0	0	0	0	0
IPW56	0	0	0	0	0	0	0	0	0	0
Painting plan										
202E	0	0	0	0	0	0	0	0	0	0
202P	0	0	0	0	0	0	0	0	0	0
211E	0	0	0	0	0	0	0	0	0	0
211P	0	0	0	0	0	0	0	0	0	0
212E	0	0	0	0	0	0	0	0	0	0
212P	0	0	0	0	0	0	0	0	0	0
213E	0	0	0	0	0	0	0	0	0	0
Painting inside of terminal box (Munsell 2.5 YR 6/14)	0	0	0	0	0	0	0	0	0	0
Internal Tropicalized Painting	0	0	0	0	0	0	0	0	0	0
Other mechanical options										
Additional grounding on the frame (outside the terminal box)	0	0	0	0	0	0	0	0	0	0
Drip cover	0	0	0	0	0	0	0	0	0	0
Rubber Slinger	0	0	0	0	0	0	0	0	0	0
Grease outlet through endshield	0	0	0	0	0	0	0	0	0	0
Electrical options										
Winding thermal protection										
Alarm thermostat	0	0	0	0	0	0	0	0	0	0
Tripping thermostat	0	0	0	0	0	0	0	0	0	0
RTD two wires, one per phase	0	0	0	0	0	0	0	0	0	0
RTD two wires, two per phase	0	0	0	0	0	0	0	0	0	0
RTD three wires, one per phase	0	0	0	0	0	0	0	0	0	0
RTD three wires, two per phase	0	0	0	0	0	0	0	0	0	0
Alarm thermistor	0	0	0	0	0	0	0	0	0	0
Tripping thermistor	0	0	0	0	0	0	0	0	0	0
Bearing thermal protection										
Thermostat	NA	NA	NA	NA	NA	NA	0	0	0	0
Thermistor	NA	NA	NA	NA	NA	NA	0	0	0	0
RTD two wires	NA	NA	NA	NA	NA	NA	0	0	0	0
RTD three wires	NA	NA	NA	NA	NA	NA	0	0	0	0
RTD three wires (calibrated)	NA	NA	NA	NA	NA	NA	0	0	0	0
Space heater										
110-127 V	0	0	0	0	0	0	0	0	0	0
220-240 V	0	0	0	0	0	0	0	0	0	0
110-127 / 220-240 V	NA	NA	0	0	0	0	0	0	0	0
380-480 V	0	0	0	0	0	0	0	0	0	0
Insulation class										
F	S	S	S	S	S	S	S	S	S	S
H	0	0	0	0	0	0	0	0	0	0
Forced ventilation kit										
Forced ventilation kit with encoder provision (specify kit voltage)	0	0	0	0	0	0	0	0	0	0
Forced ventilation kit without encoder provision (specify kit voltage)	0	0	0	0	0	0	0	0	0	0
Encoder	0	0	0	0	0	0	0	0	0	0
Drive end side grounding brush	NA	NA	NA	NA	NA	NA	NA	NA	NA	NA
Non drive end side grounding brush	NA	NA	NA	NA	NA	NA	NA	NA	NA	NA
AEGIS SGR™ Bearing Protection Ring Kit	0	0	0	0	0	0	0	0	0	0

Notes: 1) Other optional features, on request.

2) Some combinations of optional features are not allowed - then contact WEG.

S (Standard)

NA (Not available)

O (Optional)

Frame	324T	326T	364/5T	404/5T	444/5T	445/7T	447/9T	L447/9T	504/5T	586/7T	588/9T
Drain											
Rubber drain plug	S	S	S	S	S	S	S	S	S	S	S
Threaded drain plug	0	0	0	0	0	0	0	0	0	0	0
Stainless steel threaded drain plug (closed)	0	0	0	0	0	0	0	0	0	0	0
T-type drain plug (opened)	0	0	0	0	0	0	0	0	0	0	0
Degree of protection											
IP56	0	0	0	0	0	0	0	0	0	0	0
IP65	0	0	0	0	0	0	0	0	0	0	0
IP66	0	0	0	0	0	0	0	0	0	0	0
IPW55	0	0	0	0	0	0	0	0	0	0	0
IPW56	0	0	0	0	0	0	0	0	0	0	0
Painting plan											
202E	0	0	0	0	0	0	0	0	0	0	0
202P	0	0	0	0	0	0	0	0	0	0	0
211E	0	0	0	0	0	0	0	0	0	0	0
211P	0	0	0	0	0	0	0	0	0	0	0
212E	0	0	0	0	0	0	0	0	0	0	0
212P	0	0	0	0	0	0	0	0	0	0	0
213E	0	0	0	0	0	0	0	0	0	0	0
Painting inside of terminal box (Munsell 2.5 YR 6/14)	0	0	0	0	0	0	0	0	0	0	0
Internal Tropicalized Painting	0	0	0	0	0	0	0	0	0	0	0
Other mechanical options											
Additional grounding on the frame (outside the terminal box)	0	0	0	0	0	0	0	0	0	0	0
Drip cover	0	0	0	0	0	0	0	0	0	0	0
Rubber Slinger	0	0	0	0	0	0	0	0	0	0	0
Grease outlet through endshield	0	0	0	0	0	0	0	0	0	0	0
Electrical options											
Winding thermal protection											
Alarm thermostat	0	0	0	0	0	0	0	0	0	0	0
Tripping thermostat	0	0	0	0	0	0	0	0	0	0	0
RTD two wires, one per phase	0	0	0	0	0	0	0	0	0	0	0
RTD two wires, two per phase	0	0	0	0	0	0	0	0	0	0	0
RTD three wires, one per phase	0	0	0	0	0	0	0	0	0	0	0
RTD three wires, two per phase	0	0	0	0	0	0	0	0	0	0	0
Alarm thermistor	0	0	0	0	0	0	0	0	0	0	0
Tripping thermistor	0	0	0	0	0	0	0	0	0	0	0
Bearing thermal protection											
Thermostat	0	0	0	0	0	0	0	0	0	0	0
Thermistor	0	0	0	0	0	0	0	0	0	0	0
RTD two wires	0	0	0	0	0	0	0	0	0	0	0
RTD three wires	0	0	0	0	0	0	0	0	0	0	0
RTD three wires (calibrated)	0	0	0	0	0	0	0	0	0	0	0
Space heater											
110-127 V	0	0	0	0	0	0	0	0	0	0	0
220-240 V	0	0	0	0	0	0	0	0	0	S	S
110-127 / 220-240 V	0	0	0	0	0	0	0	0	0	0	0
380-480 V	0	0	0	0	0	0	0	0	0	0	0
Insulation class											
F	S	S	S	S	S	S	S	S	S	S	S
H	0	0	0	0	0	0	0	0	0	0	0
Forced ventilation kit											
Forced ventilation kit with encoder provision (specify kit voltage)	0	0	0	0	0	0	0	0	0	0	0
Forced ventilation kit without encoder provision (specify kit voltage)	0	0	0	0	0	0	0	0	0	0	0
Encoder	0	0	0	0	0	0	0	0	0	0	0
Drive end side grounding brush	NA	NA	NA	NA	NA	0	0	0	0	0	0
Non drive end side grounding brush	NA	NA	0	0	0	0	0	0	0	0	0
AEGIS SGR™ Bearing Protection Ring Kit	0	0	0	0	0	0	0	0	0	0	0

14. Electrical Data

W22 - High Efficiency

Output		Frame	Full Load Torque (ft.lb)	Locked Rotor Current		Locked Rotor Torque Tl/Tn	Break-down Torque Tb/Tn	Inertia J (sq. ft.lb)	Allowable locked rotor time (s)		Weight (lb)	Sound dB(A)	Service Factor	460 V						Full load current In (A)	
				Code	I/In				Hot	Cold				Rated speed (rpm)	Efficiency			Power Factor			
															50	75	100	50	75		100
II Poles																					
1	0,75	143/5T	1,49	K	7,0	2,3	2,8	0,0278	13	29	34,2	68,0	1,25	3480	72,0	75,5	75,5	0,69	0,79	0,84	1,48
1,5	1,1	143/5T	2,25	J	6,8	2,5	3,0	0,0370	13	29	38,6	68,0	1,25	3455	78,5	82,5	82,5	0,68	0,78	0,84	1,99
2	1,5	143/5T	3,00	J	7,4	2,5	3,0	0,0427	16	35	41,9	68,0	1,25	3450	81,5	84,0	84,0	0,69	0,80	0,85	2,64
3	2,2	182/4T	4,44	H	7,2	2,0	3,1	0,1644	28	62	84,9	69,0	1,25	3500	82,5	85,5	85,5	0,76	0,84	0,88	3,67
5	3,7	182/4T	7,42	H	7,3	2,0	3,0	0,1906	27	59	88,2	69,0	1,25	3490	85,5	87,5	87,5	0,78	0,86	0,89	5,90
5	3,7	L184T	7,42	H	7,3	2,0	3,0	0,1906	27	59	88,2	69,0	1,25	3490	85,5	87,5	87,5	0,78	0,86	0,89	5,90
7,5	5,5	213/5T	11,1	H	6,7	2,1	3,0	0,3842	18	40	128	72,0	1,25	3510	87,5	88,5	88,5	0,75	0,84	0,88	8,86
10	7,5	213/5T	14,7	H	7,1	2,1	2,9	0,4680	19	42	143	72,0	1,25	3515	88,5	89,5	89,5	0,79	0,87	0,90	11,7
15	11	254/6T	22,1	G	6,2	2,0	2,5	1,26	18	40	225	72,0	1,25	3520	89,5	90,2	90,2	0,78	0,86	0,88	17,4
20	15	254/6T	29,4	G	6,0	2,0	2,5	1,54	15	33	265	72,0	1,25	3520	90,2	90,2	90,2	0,78	0,85	0,88	23,7
25	18,5	284/6T	36,7	F	6,0	2,0	2,4	2,29	15	33	344	72,0	1,25	3530	91,0	91,0	91,0	0,83	0,88	0,90	29,0
30	22	284/6T	44,0	F	6,0	2,0	2,4	2,83	14	31	375	72,0	1,25	3530	91,0	91,0	91,0	0,82	0,88	0,90	33,7
40	30	324/6T	58,4	F	6,0	2,1	2,3	4,90	22	48	516	76,0	1,25	3550	91,0	91,7	91,7	0,83	0,88	0,89	46,1
50	37	324/6T	72,9	F	6,2	2,3	2,3	5,32	18	40	549	76,0	1,25	3555	91,7	92,4	92,4	0,83	0,88	0,89	56,5
60	45	364/5TS	87,6	G	6,3	2,0	2,4	8,51	15	33	807	80,0	1,25	3550	91,7	93,0	93,0	0,84	0,89	0,90	67,5
75	55	364/5TS	109	G	6,4	2,0	2,4	10,6	14	31	847	80,0	1,25	3550	93,0	93,0	93,0	0,86	0,89	0,90	82,5
100	75	404/5TS	146	F	6,2	2,0	2,2	11,9	11	24	1008	80,0	1,25	3545	93,6	94,1	93,6	0,85	0,89	0,90	112
125	90	444/5TS	181	F	6,2	1,8	2,4	27,9	24	53	1464	81,0	1,15	3570	93,0	94,1	94,5	0,80	0,86	0,88	136
150	110	444/5TS	218	F	6,3	1,9	2,4	33,5	23	51	1610	81,0	1,15	3570	94,1	95,0	94,5	0,82	0,87	0,89	164
200	150	445/7TS	291	G	6,5	2,0	2,2	44,7	18	40	1914	81,0	1,15	3565	94,5	95,0	95,0	0,86	0,88	0,89	223
250	185	447/9TS	363	F	6,5	1,9	2,4	51,4	20	44	2388	81,0	1,15	3565	94,5	95,4	95,4	0,85	0,88	0,90	270
300	220	447/9TS	435	F	6,5	2,5	2,4	58,1	14	31	2545	81,0	1,15	3575	95,4	95,4	95,4	0,86	0,89	0,90	322
350	260	586/7TS	507	F	6,5	1,6	2,4	136	25	55	3621	84,0	1,15	3580	95,4	95,8	95,8	0,87	0,90	0,91	374
400	300	586/7TS	579	F	6,5	1,8	2,2	122	48	106	3749	84,0	1,15	3580	95,4	95,8	95,8	0,88	0,90	0,91	432
450	330	586/7TS	651	F	6,6	2,0	2,3	132	36	79	3918	84,0	1,15	3580	95,4	95,8	95,8	0,88	0,90	0,91	475
500	370	586/7TS	724	G	6,8	2,2	2,4	143	39	86	4086	84,0	1,15	3580	95,4	95,8	95,8	0,88	0,90	0,91	533
High-Output Design																					
2	1,5	182/4T	2,96	J	7,0	2,0	3,1	0,1471	55	121	81,6	69,0	1,25	3500	78,5	82,5	84,0	0,74	0,82	0,87	2,58
2	1,5	L145T	3,00	J	7,4	2,5	3,0	0,0427	16	35	41,9	68,0	1,25	3450	81,5	84,0	84,0	0,69	0,80	0,85	2,64
3	2,2	143/5T	4,51	H	6,9	2,8	3,1	0,0610	11	24	51,8	68,0	1,15	3450	85,5	85,5	85,5	0,71	0,81	0,86	3,76
3	2,2	L182T	4,44	H	7,2	2,0	3,1	0,1644	28	62	84,9	69,0	1,25	3500	82,5	85,5	85,5	0,76	0,84	0,88	3,67
7,5	5,5	182/4T	11,2	H	7,2	2,2	2,9	0,2288	16	35	92,6	69,0	1,15	3470	87,5	88,5	88,5	0,83	0,88	0,90	8,48
15	11	213/5T	22,3	G	6,3	2,1	2,5	0,6402	15	33	163	72,0	1,15	3490	89,5	90,2	90,2	0,84	0,89	0,91	16,8
25	18,5	254/6T	36,8	G	6,2	2,0	2,3	1,54	11	24	273	72,0	1,15	3515	91,0	91,0	91,0	0,81	0,87	0,90	28,4
40	30	284/6TS	58,7	G	6,2	2,1	2,5	2,83	10	22	410	72,0	1,15	3530	91,7	91,7	91,7	0,82	0,88	0,90	45,6
50	37	364/5TS	73,0	G	6,3	1,9	2,4	8,51	17	37	763	80,0	1,25	3550	91,0	92,4	92,4	0,83	0,88	0,90	55,8
60	45	404/5TS	87,6	F	6,2	1,9	2,4	8,51	19	42	882	80,0	1,25	3550	91,7	92,4	93,0	0,84	0,89	0,90	67,5
60	45	324/6T	87,6	F	6,0	2,1	2,3	5,32	17	37	584	76,0	1,15	3550	92,4	93,0	93,0	0,82	0,87	0,88	69,0
100	75	364/5TS	146	J	7,9	2,2	2,9	11,9	9	20	889	80,0	1,15	3560	93,6	94,1	93,6	0,79	0,86	0,88	114
100	75	444/5TS	145	G	6,3	1,7	2,4	27,9	30	66	1389	81,0	1,25	3570	92,4	93,6	93,6	0,78	0,85	0,88	114
150	110	445/7TS	218	F	6,3	1,9	2,4	33,5	23	51	1610	81,0	1,15	3570	94,1	95,0	94,5	0,82	0,87	0,89	164
200	150	504/5TS	290	G	6,6	2,0	2,5	44,7	24	53	2168	81,0	1,15	3575	94,1	95,0	95,4	0,82	0,88	0,90	219
250	185	504/5TS	362	F	6,5	1,9	2,4	51,4	20	44	2388	81,0	1,15	3575	94,5	95,4	95,4	0,85	0,88	0,90	270
250	185	445/7TS	363	F	6,5	1,9	2,3	51,4	20	44	2159	81,0	1,15	3565	94,5	95,4	95,4	0,85	0,88	0,90	270
300	220	586/7TS	434	F	6,5	1,6	2,2	123	30	66	3382	84,0	1,15	3580	95,0	95,4	95,4	0,87	0,90	0,91	318
350	260	447/9TS	507	J	8,5	2,5	2,6	68,1	10	22	2701	81,0	1,15	3575	95,0	95,2	95,4	0,85	0,89	0,90	380

Output		Frame	Full Load Torque (ft.lb)	Locked Rotor Current		Locked Rotor Torque Tl/Tn	Break-down Torque Tb/Tn	Inertia J (sq. ft.lb)	Allowable locked rotor time (s)		Weight (lb)	Sound dB(A)	Service Factor	460 V						Full load current In (A)	
				Code	II/In				Hot	Cold				Rated speed (rpm)	% of full load			Power Factor			
															50	75	100	50	75		100

IV Poles

1	0,75	143/5T	2,93	N	8,6	2,8	3,5	0,0911	13	29	37,5	51,0	1,25	1770	78,5	82,5	82,5	0,48	0,60	0,69	1,65
1,5	1,1	143/5T	4,40	M	9,0	2,5	3,0	0,1172	14	31	40,8	51,0	1,25	1765	80,0	82,5	84,0	0,53	0,65	0,73	2,25
2	1,5	143/5T	5,94	K	7,0	2,4	2,8	0,1296	11	24	43,0	51,0	1,25	1745	82,5	84,0	84,0	0,54	0,66	0,75	2,99
3	2,2	182/4T	8,83	K	7,5	2,2	2,8	0,2636	18	40	83,8	56,0	1,25	1760	86,5	87,5	87,5	0,61	0,72	0,78	4,05
5	3,7	182/4T	14,8	J	6,8	1,9	2,6	0,3683	14	31	92,6	56,0	1,25	1750	86,5	87,5	87,5	0,60	0,72	0,80	6,63
7,5	5,5	213/5T	22,1	H	6,5	2,1	2,6	0,9800	13	29	139	58,0	1,25	1755	88,5	89,5	89,5	0,66	0,77	0,83	9,31
10	7,5	213/5T	29,5	H	6,5	2,0	2,5	1,16	12	26	154	58,0	1,25	1755	89,5	89,5	89,5	0,68	0,80	0,84	12,5
15	11	254/6T	44,0	G	6,0	2,3	2,6	2,38	15	33	227	64,0	1,25	1765	90,2	91,0	91,0	0,68	0,80	0,84	17,8
20	15	254/6T	58,9	G	6,0	2,0	2,4	2,86	14	31	262	64,0	1,25	1760	90,2	91,0	91,0	0,72	0,81	0,85	24,3
25	18,5	284/6T	73,6	G	6,1	2,2	2,4	5,11	23	51	388	64,0	1,25	1760	91,7	92,4	92,4	0,73	0,82	0,86	29,2
30	22	284/6T	88,3	F	6,0	2,3	2,4	5,32	19	42	419	64,0	1,25	1760	92,4	93,0	92,4	0,74	0,83	0,87	34,3
40	30	324/6T	117	G	6,0	2,1	2,4	7,85	18	40	463	69,0	1,25	1770	92,4	93,0	93,0	0,74	0,82	0,85	47,6
50	37	324/6T	146	F	6,0	2,2	2,4	9,16	15	33	512	69,0	1,25	1770	93,0	93,6	93,0	0,74	0,82	0,86	58,1
60	45	364/5T	176	G	6,3	2,0	2,3	17,4	12	26	800	70,0	1,25	1770	93,6	93,6	93,6	0,79	0,85	0,87	69,4
60	45	364/5TS	176	G	6,3	2,0	2,3	17,4	12	26	800	70,0	1,25	1770	93,6	93,6	93,6	0,79	0,85	0,87	69,4
75	55	364/5T	220	G	6,3	2,1	2,4	19,9	10	22	847	70,0	1,25	1770	94,1	94,1	94,1	0,79	0,85	0,87	84,3
75	55	364/5TS	220	G	6,3	2,1	2,4	19,9	10	22	847	70,0	1,25	1770	94,1	94,1	94,1	0,79	0,85	0,87	84,3
100	75	404/5T	292	F	6,1	2,1	2,4	27,4	14	31	1094	70,0	1,25	1775	94,5	94,5	94,5	0,80	0,86	0,88	113
100	75	404/5TS	292	F	6,1	2,1	2,4	27,4	14	31	1094	70,0	1,25	1775	94,5	94,5	94,5	0,80	0,86	0,88	113
125	90	444/5T	364	G	6,5	1,8	2,4	45,7	24	53	1444	73,0	1,15	1780	94,5	94,5	94,5	0,76	0,83	0,85	141
125	90	444/5TS	364	G	6,5	1,8	2,4	45,7	24	53	1444	73,0	1,15	1780	94,5	94,5	94,5	0,76	0,83	0,85	141
150	110	444/5T	437	F	6,3	1,9	2,2	57,2	23	51	1552	73,0	1,15	1780	95,0	95,0	95,0	0,78	0,84	0,87	167
150	110	444/5TS	437	F	6,3	1,9	2,2	57,2	23	51	1552	73,0	1,15	1780	95,0	95,0	95,0	0,78	0,84	0,87	167
200	150	445/7T	582	G	6,4	2,0	2,3	76,2	18	40	1828	73,0	1,15	1780	95,0	95,4	95,0	0,77	0,84	0,86	230
250	185	445/7T	728	G	6,4	2,2	2,2	89,6	16	35	2033	73,0	1,15	1780	95,0	95,4	95,4	0,78	0,84	0,86	283
300	220	447/9T	873	G	6,5	2,3	2,3	105	14	31	2375	75,0	1,15	1780	95,4	95,8	95,4	0,76	0,84	0,86	337
300	220	447/9TS	873	G	6,5	2,3	2,3	105	14	31	2375	75,0	1,15	1780	95,4	95,8	95,4	0,76	0,84	0,86	337
350	260	447/9T	1019	G	6,4	2,1	2,2	118	16	35	2644	75,0	1,15	1780	95,4	95,8	95,8	0,76	0,84	0,86	396
350	260	447/9TS	1019	G	6,4	2,1	2,2	118	16	35	2644	75,0	1,15	1780	95,4	95,8	95,8	0,76	0,84	0,86	396
400	300	586/7T	1158	G	6,4	2,0	2,2	179	19	42	3455	81,0	1,15	1790	95,4	95,8	95,8	0,77	0,84	0,86	457
400	300	586/7TS	1158	G	6,4	2,0	2,2	179	19	42	3455	81,0	1,15	1790	95,4	95,8	95,8	0,77	0,84	0,86	457
450	330	586/7T	1302	G	6,4	2,1	2,1	213	17	37	3455	81,0	1,15	1790	95,4	95,8	95,8	0,77	0,84	0,86	503
450	330	586/7TS	1302	G	6,4	2,1	2,1	213	17	37	3455	81,0	1,15	1790	95,4	95,8	95,8	0,77	0,84	0,86	503
500	370	586/7T	1447	G	6,4	2,1	2,0	256	16	35	3912	81,0	1,15	1790	95,4	95,8	95,8	0,79	0,85	0,86	564
500	370	586/7TS	1447	G	6,4	2,1	2,0	256	16	35	3912	81,0	1,15	1790	95,4	95,8	95,8	0,79	0,85	0,86	564
600	440	586/7T	1737	G	7,1	2,4	2,5	236	16	35	4335	81,0	1,00	1790	96,2	96,4	96,5	0,74	0,82	0,86	665

High-Output Design

5	3,7	213/5T	14,8	H	6,4	2,0	2,5	0,8061	20	44	132	58,0	1,25	1755	86,5	87,5	87,5	0,68	0,79	0,84	6,32
10	7,5	254/6T	29,4	G	6,0	2,1	2,4	1,91	20	44	205	64,0	1,25	1765	88,5	89,5	89,5	0,70	0,80	0,84	12,5
20	15	284/6T	58,9	G	6,0	2,0	2,3	5,11	27	59	344	64,0	1,25	1760	91,0	91,0	91,0	0,74	0,82	0,86	24,1
25	18,5	284/6TS	73,6	G	6,1	2,2	2,4	5,11	23	51	388	64,0	1,25	1760	91,7	92,4	92,4	0,73	0,82	0,86	29,2
30	22	284/6TS	88,3	F	6,0	2,3	2,4	5,32	19	42	419	64,0	1,25	1760	92,4	93,0	92,4	0,74	0,83	0,87	34,3
50	37	364/5T	146	F	6,0	1,9	2,2	17,4	15	33	754	70,0	1,25	1770	93,0	93,0	93,0	0,79	0,85	0,87	57,4
60	45	324/6T	176	G	6,0	2,1	2,4	9,16	14	31	595	69,0	1,15	1770	93,0	93,6	93,6	0,73	0,81	0,85	71,0
60	45	324/6TS	176	G	6,0	2,1	2,4	9,16	14	31	595	69,0	1,15	1770	93,0	93,6	93,6	0,73	0,81	0,85	71,0
75	55	404/5T	219	G	6,5	2,2	2,4	19,9	22	48	950	70,0	1,25	1775	94,1	94,1	94,1	0,79	0,86	0,88	83,4
75	55	404/5TS	219	G	6,5	2,2	2,4	19,9	22	48	950	70,0	1,25	1775	94,1	94,1	94,1	0,79	0,86	0,88	83,4
100	75	444/5T	291	G	6,2	1,8	2,4	33,1	24	53	1367	73,0	1,25	1780	94,1	94,5	94,5	0,74	0,82	0,85	117
100	75	444/5TS	291	G	6,2	1,8	2,4	33,1	24	53	1367	73,0	1,25	1780	94,1	94,5	94,5	0,74	0,82	0,85	117
150	110	504/5T	434	F	6,2	1,9	2,3	57,2	28	62	1890	75,0	1,15	1790	93,6	94,5	95,0	0,76	0,83	0,86	169
150	110	504/5TS	434	F	6,2	1,9	2,3	57,2	28	62	1890	75,0	1,15	1790	93,6	94,5	95,0	0,76	0,83	0,86	169
200	150	444/5T	582	G	6,4	2,0	2,3	76,2	18	40	1828	73,0	1,15	1780	95,0	95,4	95,0	0,77	0,84	0,86	230
200	150	444/5TS	582	G	6,4	2,0	2,3	76,2	18	40	1828	73,0	1,15	1780	95,0	95,4	95,0	0,77	0,84	0,86	230
200	150	447/9T	582	G	6,4	2,0	2,3	76,2	18	40	1828	75,0	1,15	1780	95,0	95,4	95,0	0,77	0,84	0,86	230
200	150	447/9TS	582	G	6,4	2,0	2,3	76,2	18	40	1828	75,0	1,15	1780	95,0	95,4	95,0	0,77	0,84	0,86	230
200	150	504/5T	580	G	6,2	2,0	2,1	76,2	21	46	2145	75,0	1,15	1785	94,5	95,0	95,0	0,77	0,84	0,86	230
200	150	504/5TS	580	G	6,2	2,0	2,1	76,2	21	46	2145	75,0	1,15	1785	94,5	95,0	95,0	0,77	0,84	0,86	230
250	185	447/9T	728	G	6,4	2,2	2,2	89,6	16	35	2033	75,0	1,15	1780	95,0	95,4	95,4	0,78	0,84	0,86	283
250	185	447/9TS	728	G	6,4	2,2	2,2	89,6	16	35	2033	75,0	1,15	1780	95,0	95,4	95,4	0,78	0,84	0,86	283
250	185	504/5T	726	G	6,4	2,1	2,1	89,6	21	46	2337	75,0	1,15	1785	95,0	95,4	95,4	0,77	0,84	0,86	283
250	185	504/5TS	726	G	6,4	2,1	2,1	89,6	21	46	2337	75,0	1,15	1785	95,0	95,4	95,4	0,77	0,84	0,86	283
250	185	445/7TS	728	G	6,4	2,2	2,2	89,6	16	35	2033	73,0	1,15	1780	95,0	95,4	95,4	0,78	0,84	0,86	283
300	220	586/7T	868	G	6,4	1,9	2,2	163	20	44	2961	81,0	1,15	1790	95,0	95,4	95,8	0,76	0,83	0,85	339



W22 - High Efficiency

Output HP	kW	Frame	Full Load Torque (ft.lb)	Locked Rotor Current		Locked Rotor Torque Tl/Tn	Break-down Torque Tb/Tn	Inertia J (sq. ft.lb)	Allowable locked rotor time (s)		Weight (lb)	Sound dB(A)	Service Factor	460 V						Full load current In (A)	
				Code	Il/In				Hot	Cold				Rated speed (rpm)	% of full load			Power Factor			
															50	75	100	50	75		100
VI Poles																					
1	0,75	143/5T	4,51	J	5,7	2,5	2,8	0,1303	23	51	44,1	49,0	1,25	1150	75,5	80,0	80,0	0,50	0,63	0,72	1,63
1,5	1,1	182/4T	6,70	J	6,0	2,0	2,6	0,4786	55	121	68,4	52,0	1,25	1160	81,5	84,0	85,5	0,53	0,65	0,72	2,24
2	1,5	182/4T	8,93	J	6,0	2,1	2,6	0,5657	47	103	79,4	52,0	1,25	1160	84,0	86,5	86,5	0,54	0,66	0,73	2,98
3	2,2	213/5T	13,3	H	6,1	1,8	2,4	0,9933	76	167	110	55,0	1,25	1170	84,0	86,5	87,5	0,56	0,68	0,74	4,15
5	3,7	213/5T	22,2	J	6,4	2,1	2,3	1,47	35	77	162	55,0	1,25	1165	86,5	87,5	87,5	0,55	0,67	0,75	7,08
7,5	5,5	254/6T	33,1	G	6,1	2,0	2,7	2,56	23	51	227	59,0	1,25	1175	87,5	88,5	89,5	0,62	0,74	0,80	9,64
10	7,5	254/6T	44,3	G	6,0	2,0	2,6	2,90	20	44	251	59,0	1,25	1170	88,5	89,5	89,5	0,63	0,75	0,80	13,1
15	11	284/6T	66,1	G	6,0	2,2	2,5	7,20	17	37	344	59,0	1,25	1175	90,2	90,2	90,2	0,72	0,81	0,86	17,8
20	15	284/6T	88,2	G	6,1	2,1	2,4	8,18	16	35	390	59,0	1,25	1175	90,2	91,0	91,0	0,73	0,82	0,86	24,1
25	18,5	324/6T	110	F	5,7	2,0	2,4	10,2	19	42	448	62,0	1,25	1175	91,0	91,7	91,7	0,69	0,79	0,83	30,5
30	22	324/6T	132	F	5,8	2,0	2,4	11,9	18	40	492	62,0	1,25	1175	91,0	91,7	91,7	0,69	0,79	0,84	35,8
40	30	364/5T	176	G	6,2	1,9	2,3	23,5	16	35	770	66,0	1,25	1180	93,0	93,0	93,0	0,74	0,83	0,86	47,1
50	37	364/5T	220	G	6,2	1,9	2,3	29,0	15	33	816	66,0	1,25	1180	93,0	93,0	93,0	0,75	0,83	0,86	58,1
50	37	364/5TS	220	G	6,2	1,9	2,3	29,0	15	33	816	66,0	1,25	1180	93,0	93,0	93,0	0,75	0,83	0,86	58,1
60	45	404/5T	263	G	6,1	2,0	2,3	34,6	16	35	1005	68,0	1,25	1180	93,6	93,6	93,6	0,75	0,83	0,86	70,2
75	55	404/5T	329	F	6,1	2,0	2,2	36,9	13	29	1054	68,0	1,25	1180	93,6	93,6	93,6	0,76	0,84	0,86	85,8
100	75	444/5T	437	G	6,0	2,0	2,2	73,6	16	35	1422	69,0	1,25	1185	94,1	94,1	94,1	0,70	0,80	0,83	121
125	90	444/5T	547	F	6,0	2,0	2,2	87,3	19	42	1599	69,0	1,15	1185	94,1	94,5	94,1	0,72	0,80	0,84	143
150	110	445/7T	656	G	6,1	2,0	2,2	109	19	42	1810	69,0	1,15	1185	94,5	95,0	95,0	0,73	0,80	0,84	173
200	150	445/7T	874	G	6,1	2,1	2,2	134	15	33	2093	69,0	1,15	1185	94,5	95,0	95,0	0,72	0,81	0,84	236
250	185	447/9T	1093	G	6,2	2,2	2,2	153	11	24	2452	70,0	1,15	1185	95,0	95,4	95,0	0,71	0,80	0,84	291
300	220	447/9T	1312	H	6,9	2,4	2,4	169	10	22	2613	70,0	1,15	1185	95,0	95,4	95,0	0,69	0,79	0,83	350
300	220	447/9TS	1312	H	6,9	2,4	2,4	169	10	22	2613	70,0	1,15	1185	95,0	95,4	95,0	0,69	0,79	0,83	350
350	260	586/7T	1524	G	6,1	1,8	2,1	328	29	64	3784	77,0	1,15	1190	95,0	95,4	95,4	0,66	0,77	0,81	422
400	300	586/7T	1741	G	6,1	2,2	2,1	368	29	64	4115	77,0	1,15	1190	95,0	95,4	95,4	0,67	0,77	0,81	487
450	330	586/7T	1959	G	6,1	2,1	2,1	368	26	57	4384	77,0	1,00	1190	95,0	95,4	95,4	0,67	0,77	0,81	536
500	370	586/7T	2177	G	6,3	2,2	2,1	368	25	55	4403	77,0	1,00	1190	95,4	95,8	95,8	0,66	0,76	0,80	606
High-Output Design																					
15	11	284/6TS	66,1	G	6,0	2,2	2,5	7,20	17	37	344	59,0	1,25	1175	90,2	90,2	90,2	0,72	0,81	0,86	17,8
20	15	284/6TS	88,2	G	6,1	2,1	2,4	8,18	16	35	390	59,0	1,25	1175	90,2	91,0	91,0	0,73	0,82	0,86	24,1
75	55	444/5T	328	G	6,0	2,0	2,2	62,7	19	42	1338	69,0	1,25	1185	93,6	94,1	93,6	0,70	0,80	0,83	88,9
75	55	444/5TS	328	G	6,0	2,0	2,2	62,7	19	42	1338	69,0	1,25	1185	93,6	94,1	93,6	0,70	0,80	0,83	88,9
100	75	444/5TS	437	G	6,0	2,0	2,2	73,6	16	35	1422	69,0	1,25	1185	94,1	94,1	94,1	0,70	0,80	0,83	121
100	75	445/7T	437	G	6,0	2,0	2,2	73,6	16	35	1466	69,0	1,25	1185	94,1	94,1	94,1	0,70	0,80	0,83	121
100	75	445/7TS	437	G	6,0	2,0	2,2	73,6	16	35	1466	69,0	1,25	1185	94,1	94,1	94,1	0,70	0,80	0,83	121
125	90	444/5TS	547	F	6,0	2,0	2,2	87,3	19	42	1599	69,0	1,15	1185	94,1	94,5	94,1	0,72	0,80	0,84	143
150	110	504/5T	653	G	6,2	2,0	2,2	109	22	48	2097	70,0	1,15	1190	94,1	95,0	95,0	0,71	0,80	0,83	175
150	110	504/5TS	653	G	6,2	2,0	2,2	109	22	48	2097	70,0	1,15	1190	94,1	95,0	95,0	0,71	0,80	0,83	175
150	110	445/7TS	656	G	6,1	2,0	2,2	109	19	42	1810	69,0	1,15	1185	94,5	95,0	95,0	0,73	0,80	0,84	173
200	150	504/5T	871	G	6,0	2,0	2,1	134	19	42	2368	70,0	1,15	1190	95,0	95,0	95,0	0,73	0,81	0,84	236
200	150	504/5TS	871	G	6,0	2,0	2,1	134	19	42	2368	70,0	1,15	1190	95,0	95,0	95,0	0,73	0,81	0,84	236
200	150	445/7TS	874	G	6,1	2,1	2,2	134	15	33	2093	69,0	1,15	1185	94,5	95,0	95,0	0,72	0,81	0,84	236
250	185	447/9TS	1093	G	6,2	2,2	2,2	153	11	24	2452	70,0	1,15	1185	95,0	95,4	95,0	0,71	0,80	0,84	291
250	185	586/7T	1088	G	6,1	2,0	2,1	226	30	66	3206	77,0	1,15	1190	95,0	95,4	95,0	0,69	0,78	0,82	298
250	185	586/7TS	1088	G	6,1	2,0	2,1	226	30	66	3206	77,0	1,15	1190	95,0	95,4	95,0	0,69	0,78	0,82	298
300	220	586/7T	1306	G	6,0	2,0	2,0	277	30	66	3495	77,0	1,15	1190	95,0	95,4	95,4	0,69	0,78	0,81	357
300	220	586/7TS	1306	G	6,0	2,0	2,0	277	30	66	3495	77,0	1,15	1190	95,0	95,4	95,4	0,69	0,78	0,81	357
350	260	586/7TS	1524	G	6,1	1,8	2,1	328	29	64	3784	77,0	1,15	1190	95,0	95,4	95,4	0,66	0,77	0,81	422
400	300	586/7TS	1741	G	6,1	2,2	2,1	368	29	64	4115	77,0	1,15	1190	95,0	95,4	95,4	0,67	0,77	0,81	487
450	330	586/7TS	1959	G	6,1	2,1	2,1	368	26	57	4384	77,0	1,00	1190	95,0	95,4	95,4	0,67	0,77	0,81	536
500	370	586/7TS	2177	G	6,3	2,2	2,1	368	25	55	4403	77,0	1,00	1190	95,4	95,8	95,8	0,66	0,76	0,80	606

Output		Frame	Full Load Torque (ft.lb)	Locked Rotor Current		Locked Rotor Torque Tl/Tn	Break-down Torque Tb/Tn	Inertia J (sq. ft.lb)	Allowable locked rotor time (s)		Weight (lb)	Sound dB(A)	Service Factor	460 V							
				Code	I/In				Hot	Cold				Rated speed (rpm)	% of full load			Power Factor			Full load current In (A)
															50	75	100	50	75	100	
VIII Poles																					
1	0,75	182/4T	5,96	K	5,0	2,0	2,6	0,3481	49	108	88,2	50,0	1,25	870	68,0	72,0	74,0	0,41	0,52	0,62	2,05
1,5	1,1	182/4T	8,98	H	4,7	2,0	2,4	0,3918	37	81	94,8	50,0	1,25	865	74,0	75,5	77,0	0,44	0,58	0,66	2,72
2	1,5	213/5T	11,9	L	6,6	2,4	2,9	1,19	43	95	141	52,0	1,25	870	78,5	81,5	82,5	0,47	0,53	0,66	3,46
3	2,2	213/5T	18,0	K	7,1	2,0	2,1	2,02	30	66	159	52,0	1,25	865	82,5	84,0	84,0	0,59	0,70	0,76	4,33
5	3,7	254/6T	29,4	H	5,5	2,0	2,6	2,90	33	73	243	54,0	1,25	880	82,5	84,0	85,5	0,48	0,61	0,70	7,76
7,5	5,5	254/6T	44,2	H	5,5	2,0	2,6	3,41	25	55	276	54,0	1,25	880	82,5	85,5	85,5	0,48	0,62	0,70	11,5
10	7,5	284/6T	58,9	G	5,7	2,0	2,2	7,20	30	66	373	54,0	1,25	880	87,5	88,5	88,5	0,62	0,72	0,77	13,8
15	11	284/6T	88,3	G	5,7	2,0	2,2	8,18	22	48	417	54,0	1,25	880	87,5	88,5	88,5	0,68	0,78	0,82	19,0
20	15	324/6T	118	G	5,0	2,0	2,2	9,79	24	53	452	56,0	1,25	880	87,5	89,5	89,5	0,55	0,67	0,74	28,4
25	18,5	324/6T	147	G	5,1	2,2	2,3	11,9	19	42	509	56,0	1,25	880	87,5	89,5	89,5	0,53	0,66	0,73	35,5
30	22	364/5T	177	G	6,0	1,6	2,2	23,5	17	37	776	60,0	1,25	880	91,0	91,7	91,0	0,67	0,77	0,82	37,0
40	30	364/5T	235	G	5,7	1,6	2,1	29,0	13	29	831	60,0	1,25	880	91,0	91,7	91,0	0,67	0,77	0,82	50,5
50	37	404/5T	296	G	6,2	1,7	2,4	34,6	12	26	992	60,0	1,00	875	91,7	91,7	91,7	0,70	0,79	0,83	61,0
60	45	404/5T	353	G	6,3	1,8	2,5	36,9	11	24	1047	60,0	1,25	880	91,7	92,4	91,7	0,70	0,80	0,83	74,2
75	55	444/5T	439	F	5,6	1,7	2,0	73,6	20	44	1444	63,0	1,25	885	93,0	93,0	93,0	0,67	0,76	0,80	92,8
100	75	444/5T	585	G	5,7	1,8	2,0	87,3	18	40	1599	63,0	1,25	885	93,0	93,6	93,0	0,67	0,76	0,80	127
125	90	445/7T	732	F	5,8	1,8	2,0	104	15	33	1806	63,0	1,15	885	93,6	94,1	93,6	0,67	0,76	0,80	151
150	110	445/7T	878	F	5,7	1,7	2,0	134	15	33	1965	63,0	1,15	885	94,1	94,1	93,6	0,67	0,76	0,80	184
200	150	447/9T	1164	G	5,9	1,9	2,1	161	14	31	2430	66,0	1,15	890	94,1	94,5	94,5	0,65	0,75	0,79	252
250	185	586/7T	1447	G	6,0	1,3	2,1	358	26	57	3649	75,0	1,15	895	94,8	95,4	95,0	0,67	0,77	0,81	302
300	220	586/7T	1737	G	6,4	1,5	2,2	462	26	57	4035	75,0	1,15	895	94,8	95,4	95,0	0,66	0,77	0,81	359
350	260	586/7T	2026	G	6,4	1,5	2,2	484	22	48	4311	75,0	1,15	895	94,8	95,4	95,0	0,66	0,77	0,81	424
High-Output Design																					
10	7,5	284TS	58,9	G	5,7	2,0	2,2	7,20	30	66	373	54,0	1,25	880	87,5	88,5	88,5	0,62	0,72	0,77	13,8
15	11	284/6TS	88,3	G	5,7	2,0	2,2	8,18	22	48	417	54,0	1,25	880	87,5	88,5	88,5	0,68	0,78	0,82	19,0
100	75	445/7T	585	G	5,7	1,8	2,0	87,3	18	40	1643	63,0	1,25	885	93,0	93,6	93,0	0,67	0,76	0,80	127
125	90	504/5T	728	F	5,8	1,8	2,0	104	23	51	2110	66,0	1,15	890	93,6	94,1	93,6	0,67	0,76	0,80	151
150	110	504/5T	873	F	5,8	1,8	2,0	134	21	46	2293	66,0	1,15	890	94,1	94,5	94,1	0,68	0,77	0,81	181
200	150	586/7T	1158	G	6,0	1,3	2,1	261	40	88	3334	75,0	1,15	895	94,0	94,1	94,5	0,65	0,76	0,80	249
250	185	586/7TS	1447	G	6,0	1,3	2,1	358	26	57	3649	75,0	1,15	895	94,8	95,4	95,0	0,67	0,77	0,81	302
300	220	586/7TS	1737	G	6,4	1,5	2,2	462	26	57	4035	75,0	1,15	895	94,8	95,4	95,0	0,66	0,77	0,81	359
350	260	586/7TS	2026	G	6,4	1,5	2,2	484	22	48	4311	75,0	1,15	895	94,8	95,4	95,0	0,66	0,77	0,81	424



W22 - NEMA Premium Efficiency

Output HP	kW	Frame	Full Load Torque (ft.lb)	Locked Rotor Current		Locked Rotor Torque Tl/Tn	Break-down Torque Tb/Tn	Inertia J (sq.ft.lb)	Allowable locked rotor time (s)		Weight (lb)	Sound dB(A)	Service Factor	460 V						Full load current In (A)	
				Code	Il/In				Hot	Cold				Rated speed (rpm)	% of full load			Power Factor			
															50	75	100	50	75		100
1	0,75	143/5T	1,49	L	8,2	2,8	3,4	0,0332	22	48	36,4	68,0	1,25	3480	75,0	79,0	81,5	0,63	0,74	0,80	1,44
1,5	1,1	143/5T	2,23	L	8,9	3,5	3,8	0,0470	21	46	40,8	68,0	1,25	3490	81,5	84,0	84,0	0,70	0,80	0,84	1,96
2	1,5	143/5T	2,98	L	8,9	3,5	3,8	0,0605	17	37	51,8	68,0	1,25	3475	82,5	85,5	85,5	0,71	0,80	0,86	2,56
3	2,2	182/4T	4,42	K	8,6	2,5	3,8	0,1889	41	90	88,2	69,0	1,25	3515	82,5	86,5	86,5	0,75	0,84	0,88	3,63
5	3,7	182/4T	7,43	J	7,6	2,3	3,5	0,2233	25	55	100,0	69,0	1,25	3485	86,5	88,5	88,5	0,76	0,85	0,89	5,90
7,5	5,5	213/5T	11,0	H	7,2	2,1	3,0	0,4665	27	59	154	72,0	1,25	3520	87,5	89,5	89,5	0,75	0,84	0,88	8,76
10	7,5	213/5T	14,7	H	7,2	2,2	2,9	0,6362	24	53	163	72,0	1,25	3520	89,5	90,2	90,2	0,79	0,87	0,90	11,6
15	11	254/6T	22,0	G	6,7	2,2	2,7	1,26	25	55	236	72,0	1,25	3530	89,5	91,0	91,0	0,77	0,85	0,88	17,2
20	15	254/6T	29,4	G	6,1	2,0	2,4	1,54	21	46	269	72,0	1,25	3520	91,0	91,7	91,0	0,82	0,87	0,89	23,2
25	18,5	284/6TS	36,6	G	6,3	2,0	2,5	2,69	17	37	362	72,0	1,25	3535	91,0	91,7	91,7	0,82	0,87	0,89	28,5
30	22	284/6TS	44,0	G	6,3	2,0	2,5	3,37	15	33	392	72,0	1,25	3535	91,7	91,7	91,7	0,82	0,87	0,89	33,8
40	30	324/6TS	58,3	G	6,3	2,3	2,4	4,90	22	48	547	78,0	1,25	3555	91,7	92,4	92,4	0,82	0,87	0,89	45,8
50	37	324/6TS	73,0	F	6,2	2,2	2,3	5,75	23	51	584	78,0	1,25	3550	93,0	93,0	93,0	0,83	0,87	0,89	56,1
60	45	364/5TS	87,3	G	6,6	2,0	2,6	10,6	14	31	825	79,0	1,25	3560	91,7	93,0	93,6	0,81	0,88	0,90	67,0
75	55	364/5TS	109	G	6,7	2,0	2,6	11,9	10	22	847	79,0	1,25	3555	92,4	93,6	93,6	0,83	0,88	0,90	81,9
100	75	404/5TS	146	G	6,5	2,0	2,4	13,2	14	31	1045	79,0	1,25	3545	93,0	94,1	94,1	0,85	0,90	0,91	110
125	90	444/5TS	181	G	6,6	2,0	2,5	33,5	29	64	1633	81,0	1,15	3570	93,6	94,5	95,0	0,82	0,87	0,89	134
150	110	444/5TS	218	G	6,5	1,8	2,4	39,1	22	48	1709	81,0	1,15	3570	94,1	95,0	95,0	0,83	0,88	0,89	163
200	150	445/7TS	290	G	6,5	2,1	2,3	44,7	14	31	1914	81,0	1,15	3570	95,0	95,4	95,4	0,86	0,89	0,90	219
250	185	447/9TS	363	F	6,5	2,0	2,2	50,3	18	40	2159	81,0	1,15	3565	95,4	95,8	95,8	0,87	0,90	0,91	266
300	220	447/9TS	435	G	6,8	2,1	2,4	58,1	14	31	2545	81,0	1,15	3570	95,4	95,8	95,8	0,86	0,89	0,90	320
350	260	586/7TS	507	G	6,6	1,6	2,3	136	28	62	3621	84,0	1,15	3580	95,4	96,2	96,2	0,86	0,90	0,91	373
400	300	586/7TS	579	G	6,8	1,8	2,2	122	48	106	3749	84,0	1,15	3580	95,8	96,2	96,2	0,88	0,90	0,91	430
450	330	586/7TS	650	F	6,6	2,0	2,3	132	34	75	3918	84,0	1,15	3585	95,8	96,2	96,2	0,88	0,90	0,91	473
500	370	586/7TS	724	G	6,8	2,2	2,4	143	39	86	4086	84,0	1,15	3580	95,8	96,2	96,2	0,88	0,90	0,91	530
550	400	588/9TS	795	K	9,6	2,3	2,7	155	33	73	4410	89,0	1,00	3585	96,0	96,5	96,5	0,84	0,89	0,90	578
600	440	588/9TS	867	H	7,4	2,3	2,7	155	33	73	4410	89,0	1,00	3585	96,0	96,5	96,5	0,84	0,89	0,90	650
650	480	588/9TS	939	G	7,1	2,0	2,4	176	56	123	4635	89,0	1,00	3585	96,1	96,6	96,6	0,86	0,90	0,91	685
700	515,2	588/9TS*	1012	G	7,2	2,3	2,5	183	34	75	4805	89,0	1,00	3585	96,2	96,6	96,6	0,86	0,90	0,91	736

High-Output Design

2	1,5	182/4T	2,94	L	9,5	2,9	4,8	0,1718	47	103	86,0	69,0	1,25	3530	78,5	84,0	85,5	0,68	0,79	0,84	2,62
3	2,2	143/5T	4,49	J	8,1	3,3	3,6	0,0605	14	31	51,8	68,0	1,25	3460	85,5	86,5	86,5	0,70	0,81	0,86	3,71
3	2,2	L182T	4,42	K	8,6	2,5	3,8	0,1889	41	90	88,2	69,0	1,25	3515	82,5	86,5	86,5	0,75	0,84	0,88	3,63
5	3,7	L182/4T	7,43	J	7,6	2,3	3,5	0,2233	25	55	100,0	69,0	1,25	3485	86,5	88,5	88,5	0,76	0,85	0,89	5,90
7,5	5,5	182/4T	11,1	J	8,2	2,7	3,3	0,2242	17	37	92,6	69,0	1,25	3485	88,5	89,5	89,5	0,75	0,84	0,88	8,76
15	11	213/5T	22,1	H	7,6	2,4	2,8	0,6362	14	31	163	72,0	1,25	3510	90,2	91,0	91,0	0,76	0,85	0,89	17,0
25	18,5	254/6T	36,8	G	6,2	2,2	2,8	1,64	16	35	309	72,0	1,25	3520	91,0	91,5	91,7	0,82	0,87	0,89	28,5
50	37	364/5TS	72,8	G	6,3	2,0	2,4	6,76	41	90	816	79,0	1,25	3560	92,0	92,5	93,0	0,81	0,88	0,89	56,1
60	45	404/5TS	87,4	G	6,5	2,0	2,5	10,6	22	48	911	79,0	1,25	3555	91,7	93,0	93,6	0,82	0,88	0,90	67,0
100	75	444/5TS	145	F	6,1	2,0	2,5	27,1	40	88	1577	81,0	1,25	3570	93,6	94,0	94,1	0,82	0,87	0,89	112
150	110	447/9TS	217	F	6,2	2,2	2,3	36,9	15	33	1892	81,0	1,25	3575	94,5	94,8	95,0	0,86	0,89	0,90	161
200	150	447/9TS	291	G	6,5	2,0	2,5	44,7	17	37	2168	81,0	1,15	3565	94,1	95,0	95,4	0,81	0,87	0,89	222
200	150	504/5TS	290	G	6,8	2,0	2,7	44,7	17	37	2168	81,0	1,15	3575	94,1	95,0	95,4	0,81	0,87	0,89	222
250	185	504/5TS	362	G	7,0	2,0	2,4	50,3	23	51	2388	81,0	1,15	3575	95,0	95,8	95,8	0,85	0,89	0,90	269
250	185	445/7TS	363	F	6,5	2,1	2,3	50,3	18	40	2159	81,0	1,15	3565	95,4	95,8	95,8	0,87	0,90	0,91	266
300	220	586/7TS	434	F	6,5	1,6	2,2	123	35	77	3382	84,0	1,15	3580	95,0	95,8	95,8	0,87	0,90	0,91	317
350	260	447/9TS	508	G	7,0	2,4	2,5	68,1	10	22	2701	81,0	1,15	3570	95,4	96,2	96,2	0,85	0,89	0,90	377
400	300	L447/9TS	579	G	6,7	2,2	2,5	91,9	25	55	3158	88,0	1,15	3580	95,4	95,8	95,8	0,85	0,90	0,91	432
450	330	L447/9TS	652	G	7,2	2,4	2,6	100	26	57	3268	88,0	1,00	3575	95,4	95,8	95,8	0,84	0,89	0,91	475

* Motor with class F (105K) temperature rise.

Output		Frame	Full Load Torque (ft.lb)	Locked Rotor Current		Locked Rotor Torque Tl/Tn	Break-down Torque Tb/Tn	Inertia J (sq.ft.lb)	Allowable locked rotor time (s)		Weight (lb)	Sound dB(A)	Service Factor	460 V							Full load current In (A)	
				Code	I/In				Hot	Cold				Rated speed (rpm)	% of full load			Power Factor				
															50	75	100	50	75	100		
IV Poles																						
1	0,75	143/5T	2,94	L	8,4	3,2	3,5	0,1172	18	40	40,8	51,0	1,25	1760	80,0	84,0	85,5	0,55	0,68	0,75	1,47	
1,5	1,1	143/5T	4,43	L	8,4	2,5	3,4	0,1431	14	31	48,5	51,0	1,25	1755	82,5	85,5	86,5	0,60	0,70	0,79	2,02	
2	1,5	143/5T	5,90	K	8,0	2,7	3,2	0,1561	11	24	51,1	51,0	1,25	1755	85,5	86,5	86,5	0,57	0,70	0,79	2,76	
3	2,2	182/4T	8,83	K	8,1	2,3	3,4	0,3401	23	51	90,4	56,0	1,25	1760	87,5	88,5	89,5	0,61	0,73	0,79	3,91	
5	3,7	182/4T	14,8	J	7,5	2,3	3,2	0,4003	15	33	94,8	56,0	1,25	1755	88,5	89,5	89,5	0,62	0,74	0,80	6,45	
7,5	5,5	213/5T	22,0	H	7,1	2,2	3,1	1,34	20	44	166	58,0	1,25	1765	89,5	91,0	91,7	0,66	0,76	0,82	9,18	
10	7,5	213/5T	29,4	H	6,4	2,0	3,0	1,51	17	37	179	58,0	1,25	1765	91,0	91,7	91,7	0,66	0,77	0,83	12,4	
15	11	254/6T	44,0	G	6,4	2,3	2,7	2,62	17	37	251	64,0	1,25	1765	91,0	91,7	92,4	0,68	0,78	0,83	18,0	
20	15	254/6T	58,7	H	6,9	2,3	2,7	3,10	15	33	291	64,0	1,25	1765	91,7	92,4	93,0	0,68	0,79	0,84	24,1	
25	18,5	284/6T	73,4	G	6,2	2,4	2,7	5,11	24	53	388	63,0	1,25	1765	92,4	93,0	93,6	0,70	0,80	0,84	29,5	
30	22	284/6T	88,1	G	6,1	2,4	2,4	5,85	20	44	437	63,0	1,25	1765	93,0	93,0	93,6	0,70	0,80	0,84	35,1	
40	30	324/6T	117	G	6,1	2,2	2,4	9,16	20	44	492	66,0	1,25	1775	93,6	94,1	94,1	0,72	0,80	0,85	47,1	
50	37	324/6T	146	G	6,2	2,3	2,7	9,16	15	33	536	66,0	1,25	1775	93,0	94,1	94,5	0,66	0,77	0,83	59,2	
60	45	364/5T	175	G	6,6	2,4	2,6	22,4	15	33	869	67,0	1,25	1775	94,1	94,5	95,0	0,75	0,83	0,87	68,3	
75	55	364/5T	219	G	6,4	2,4	2,6	23,3	14	31	919	67,0	1,25	1775	94,5	95,0	95,4	0,73	0,82	0,86	84,1	
100	75	404/5T	292	H	7,3	2,4	2,6	29,9	13	29	1140	68,0	1,25	1775	95,0	95,0	95,4	0,77	0,84	0,88	111	
125	90	444/5T	364	G	6,5	2,0	2,3	57,2	27	59	1590	73,0	1,15	1780	95,0	95,4	95,4	0,74	0,82	0,85	139	
150	110	444/5T	437	G	6,6	2,0	2,5	66,7	27	59	1859	73,0	1,15	1780	95,4	95,8	95,8	0,74	0,82	0,85	170	
200	150	445/7T	580	G	6,8	2,3	2,5	76,2	16	35	2095	73,0	1,15	1785	95,8	96,2	96,2	0,73	0,82	0,85	230	
250	185	447/9T	728	G	6,5	2,3	2,4	89,6	15	33	2079	75,0	1,15	1780	95,8	96,2	96,2	0,75	0,83	0,86	281	
300	220	447/9T	873	G	6,5	2,3	2,3	89,6	16	35	2381	75,0	1,15	1780	95,8	96,2	96,2	0,77	0,84	0,87	330	
350	260	447/9T	1019	G	6,4	2,5	2,4	118	14	31	2675	75,0	1,15	1780	95,8	96,2	96,2	0,72	0,77	0,84	394	
400	300	586/7T	1158	G	6,3	2,0	2,2	179	19	42	3455	78,0	1,15	1790	95,8	96,2	96,2	0,78	0,85	0,86	455	
450	330	586/7T	1302	G	6,4	2,2	2,1	213	16	35	3640	78,0	1,15	1790	95,8	96,2	96,2	0,78	0,83	0,85	507	
500	370	586/7T	1447	G	6,5	2,2	2,3	256	16	35	3912	78,0	1,00	1790	95,8	96,2	96,2	0,80	0,85	0,87	555	
550	400	586/7T	1592	G	7,1	2,2	2,5	236	16	35	4335	78,0	1,00	1790	96,2	96,4	96,5	0,74	0,82	0,86	605	
600	440	586/7T	1737	G	7,1	2,3	2,5	236	16	35	4335	78,0	1,00	1790	96,2	96,4	96,5	0,74	0,82	0,86	665	
650	480	588/9T	1881	H	7,4	2,5	2,7	301	22	48	4395	81,0	1,00	1790	96,0	96,5	96,6	0,71	0,81	0,85	734	
700	515,2	588/9T	2026	G	6,5	2,5	2,2	335	23	51	4584	81,0	1,00	1790	96,2	96,5	96,6	0,76	0,81	0,85	788	
750	550	588/9T	2171	H	7,2	2,4	2,5	347	29	64	4952	81,0	1,00	1790	96,3	96,6	96,7	0,70	0,80	0,85	840	
IV Poles - High-Output Design																						
3	2,2	L182T	8,83	K	8,1	2,3	3,4	0,3401	23	51	90,4	56,0	1,25	1760	87,5	88,5	89,5	0,61	0,73	0,79	3,91	
5	3,7	213/5T	14,7	J	7,1	2,3	3,2	1,07	20	44	132	58,0	1,25	1765	88,5	89,5	89,5	0,64	0,75	0,81	6,41	
5	3,7	L182/4T	14,8	J	7,5	2,3	3,2	0,4003	15	33	94,8	56,0	1,25	1755	88,5	89,5	89,5	0,62	0,74	0,80	6,45	
7,5	5,5	L213T	22,0	H	7,1	2,2	3,1	1,34	20	44	154	58,0	1,25	1765	89,5	91,0	91,7	0,66	0,76	0,82	9,18	
10	7,5	254/6T	29,3	G	6,3	2,2	2,8	3,13	34	75	221	64,0	1,25	1770	91,0	91,5	91,7	0,68	0,80	0,83	12,4	
20	15	284/6T	58,7	G	6,0	2,3	2,6	5,11	27	59	370	63,0	1,25	1765	92,4	93,0	93,0	0,70	0,80	0,84	24,1	
30	22	324/6T	87,6	G	6,2	2,1	2,4	8,18	26	57	463	66,0	1,25	1775	92,4	93,6	93,6	0,72	0,81	0,84	35,1	
50	37	364/5T	146	G	6,4	2,1	2,5	15,6	25	55	847	67,0	1,25	1775	93,8	94,0	94,5	0,73	0,82	0,85	57,8	
75	55	404/5T	218	G	7,0	2,3	2,6	25,4	33	73	1118	68,0	1,25	1780	95,0	95,0	95,4	0,77	0,84	0,88	82,2	
100	75	444/5T	291	G	6,1	1,8	2,3	45,5	27	59	1566	73,0	1,25	1780	95,0	95,4	95,4	0,74	0,82	0,85	116	
125	90	445/7T	364	G	6,5	2,0	2,3	57,2	27	59	1590	73,0	1,15	1780	95,0	95,4	95,4	0,74	0,82	0,85	139	
150	110	504/5T	434	E	5,5	1,7	2,0	81,1	28	62	2249	75,0	1,25	1790	95,0	95,5	95,8	0,75	0,83	0,86	168	
150	110	445/7T	437	G	6,6	2,0	2,5	66,7	27	59	1676	73,0	1,15	1780	95,4	95,8	95,8	0,74	0,82	0,85	170	
200	150	444/5T	580	G	6,8	2,3	2,5	76,2	16	35	2095	73,0	1,15	1785	95,8	96,2	96,2	0,73	0,82	0,85	230	
200	150	447/9T	582	G	6,8	2,4	2,5	76,2	16	35	1899	75,0	1,15	1780	95,4	96,2	96,2	0,73	0,82	0,85	230	
200	150	504/5T	579	G	6,3	2,2	2,2	76,2	22	48	2273	75,0	1,15	1790	95,4	96,2	96,2	0,75	0,83	0,86	228	
250	185	504/5T	726	G	6,5	2,3	2,2	89,6	20	44	2450	75,0	1,15	1785	95,8	96,2	96,2	0,78	0,85	0,87	277	
250	185	445/7T	728	G	6,5	2,3	2,4	89,6	15	33	2079	73,0	1,15	1780	95,8	96,2	96,2	0,75	0,83	0,86	281	
300	220	586/7T	868	G	6,8	2,3	2,3	161	19	42	3080	78,0	1,15	1790	95,4	96,2	96,2	0,77	0,84	0,86	334	
350	260	586/7T	1013	G	6,4	2,0	2,0	179	23	51	2675	78,0	1,15	1790	95,8	96,2	96,2	0,76	0,84	0,86	394	
350	260	L447/9T	1013	G	6,9	2,6	2,5	131	45	99	2867	77,0	1,15	1790	95,8	96,2	96,2	0,76	0,83	0,86	394	
400	300	L447/9T	1161	G	6,5	2,5	2,6	136	21	46	3285	79,0	1,15	1785	95,4	95,8	96,2	0,80	0,85	0,88	445	
450	330	L447/9T	1306	G	6,9	2,6	2,5	152	22	48	3396	79,0	1,15	1785	95,4	96,2	96,2	0,74	0,83	0,86	501	
500	370	L447/9T*	1451	H	7,2	2,5	2,6	160	22	48	3462	79,0	1,00	1785	95,4	96,2	96,2	0,73	0,82	0,86	561	

* Motor with class F (105K) temperature rise.



W22 - NEMA Premium Efficiency

Output		Frame	Full Load Torque (ft.lb)	Locked Rotor Current		Locked Rotor Torque Tl/Tn	Break-down Torque Tb/Tn	Inertia J (sq.ft.lb)	Allowable locked rotor time (s)		Weight (lb)	Sound dB(A)	Service Factor	460 V						Full load current In (A)	
				Code	I/In				Hot	Cold				Rated speed (rpm)	% of full load			Power Factor			
															50	75	100	50	75		100
VI Poles																					
1	0,75	143/5T	4,51	K	6,2	2,6	3,0	0,1595	28	62	51,5	50,0	1,25	1150	77,0	82,0	82,5	0,45	0,57	0,66	1,73
1,5	1,1	182/4T	6,64	M	7,8	3,2	4,0	0,4879	16	35	70,3	52,0	1,25	1170	84,0	86,5	87,5	0,45	0,54	0,62	2,54
2	1,5	182/4T	8,86	L	7,5	3,0	3,5	0,6210	31	68	87,5	52,0	1,25	1170	86,5	87,5	88,5	0,46	0,58	0,66	3,22
3	2,2	213/5T	13,2	K	7,0	2,0	2,8	1,20	58	128	121	55,0	1,25	1175	86,5	88,5	89,5	0,50	0,63	0,70	4,41
5	3,7	213/5T	22,1	J	6,8	1,7	2,6	1,47	57	125	170	55,0	1,25	1170	88,5	89,5	89,5	0,58	0,70	0,76	6,83
7,5	5,5	254/6T	33,1	H	6,8	2,5	3,0	3,92	30	66	262	59,0	1,25	1175	89,5	90,2	91,0	0,63	0,74	0,80	9,48
10	7,5	254/6T	44,1	H	6,5	2,3	2,8	4,43	26	57	287	59,0	1,25	1175	90,2	91,0	91,0	0,63	0,74	0,78	13,3
15	11	284/6T	66,1	G	6,4	2,3	2,7	7,85	20	44	379	59,0	1,25	1175	91,0	91,7	91,7	0,69	0,80	0,84	17,9
20	15	284/6T	88,2	G	6,2	2,3	2,6	9,16	16	35	426	59,0	1,25	1175	91,0	91,7	91,7	0,70	0,80	0,85	24,2
25	18,5	324/6T	110	G	6,2	2,1	2,6	11,5	26	57	560	62,0	1,25	1180	91,7	93,0	93,0	0,65	0,77	0,82	30,4
30	22	324/6T	132	G	6,2	2,3	2,6	13,2	21	46	628	62,0	1,25	1180	91,7	93,0	93,0	0,65	0,76	0,82	36,2
40	30	364/5T	175	G	6,4	2,0	2,4	29,0	21	46	833	66,0	1,25	1185	93,6	93,6	94,1	0,73	0,82	0,86	46,5
50	37	364/5T	220	G	6,4	2,0	2,4	32,4	18	40	869	66,0	1,25	1180	93,6	94,1	94,1	0,74	0,83	0,86	57,4
60	45	404/5T	262	H	7,1	2,0	2,3	36,9	20	44	1036	68,0	1,25	1185	94,1	94,5	94,5	0,74	0,82	0,86	69,5
75	55	404/5T	329	G	6,4	2,0	2,3	40,2	17	37	1089	68,0	1,25	1180	94,1	94,5	94,5	0,74	0,83	0,86	84,9
100	75	444/5T	437	G	6,2	2,2	2,6	87,3	20	44	1577	69,0	1,25	1185	94,5	95,0	95,0	0,68	0,78	0,82	121
125	90	444/5T	547	G	6,4	2,1	2,4	104	19	42	1751	69,0	1,15	1185	95,0	95,4	95,0	0,70	0,79	0,83	143
150	110	445/7T	656	G	6,2	2,4	2,6	134	20	44	2042	69,0	1,15	1185	95,0	95,4	95,8	0,67	0,78	0,82	176
200	150	447/9T	872	G	6,6	2,3	2,4	145	15	33	2247	70,0	1,15	1188	95,0	95,4	95,8	0,68	0,79	0,83	237
250	185	447/9T	1093	G	6,1	2,4	2,4	145	12	26	2538	70,0	1,15	1185	95,0	95,4	95,8	0,68	0,79	0,83	292
300	220	447/9T	1306	J	7,7	2,7	3,0	145	10	22	3197	70,0	1,15	1190	95,4	95,8	95,8	0,63	0,75	0,81	356
350	260	586/7T	1524	G	6,0	2,0	2,1	328	29	64	3784	77,0	1,15	1190	95,4	95,8	95,8	0,67	0,77	0,81	421
400	300	586/7T	1741	G	6,0	2,2	2,1	368	29	64	4115	77,0	1,00	1190	95,4	95,8	96,2	0,67	0,77	0,81	483
450	330	586/7T	1959	G	6,1	2,1	2,1	368	25	55	4384	77,0	1,00	1190	95,8	96,2	96,2	0,67	0,77	0,81	532
500	370	586/7T	2177	G	6,0	2,2	2,1	368	25	55	4403	77,0	1,00	1190	95,8	96,2	96,2	0,66	0,76	0,80	603
550	400	588/9T	2395	G	6,5	2,2	2,3	389	30	66	4734	77,0	1,00	1190	95,2	96,0	96,1	0,63	0,74	0,79	661
600	440	588/9T	2612	G	6,3	2,2	2,3	449	31	68	5173	77,0	1,00	1190	95,4	96,1	96,2	0,63	0,74	0,79	727

High-Output Design

2	1,5	L182/4T	8,86	L	7,5	3,0	3,5	0,6210	31	68	87,5	52,0	1,25	1170	86,5	87,5	88,5	0,46	0,58	0,66	3,22
30	22	364/5T	132	G	6,2	1,9	2,4	13,2	27	59	781	66,0	1,25	1180	93,0	93,6	93,0	0,72	0,81	0,85	34,9
50	37	404/5T	220	G	6,3	2,0	2,4	32,4	20	44	975	68,0	1,25	1180	93,6	94,1	94,1	0,73	0,82	0,85	58,1
75	55	444/5T	328	F	5,6	2,0	2,2	74,3	25	55	1555	69,0	1,25	1185	93,8	94,0	94,5	0,68	0,78	0,82	89,1
100	75	447/9T	437	G	6,2	2,2	2,6	87,3	20	44	1577	70,0	1,25	1185	94,5	95,0	95,0	0,68	0,78	0,82	121
150	110	504/5T	653	G	6,2	2,3	2,5	134	29	64	2249	70,0	1,15	1190	94,5	95,4	95,8	0,67	0,78	0,82	176
200	150	504/5T	871	G	6,2	2,2	2,3	145	21	46	2459	70,0	1,15	1190	95,0	95,4	95,8	0,70	0,80	0,83	237
200	150	445/7T	874	G	6,3	2,3	2,4	145	15	33	2247	69,0	1,15	1185	95,0	95,4	95,8	0,68	0,79	0,83	237
250	185	586/7T	1088	G	6,1	1,9	2,1	226	30	66	3206	77,0	1,15	1190	95,0	95,4	95,8	0,68	0,77	0,81	299
300	220	586/7T	1306	G	6,0	1,6	1,9	277	30	66	3495	77,0	1,15	1190	95,4	95,8	95,8	0,69	0,78	0,81	356
300	220	L447/9T	1306	G	6,7	2,5	2,4	278	18	40	3682	71,0	1,15	1190	95,7	95,8	95,8	0,72	0,81	0,84	343
350	260	L447/9T	1524	H	6,9	2,5	2,7	278	23	51	3574	71,0	1,15	1190	95,4	95,8	95,8	0,66	0,77	0,82	415
400	300	L447/9T*	1741	H	6,9	2,4	2,5	278	13	29	3682	71,0	1,00	1190	95,4	95,8	95,8	0,68	0,78	0,82	477

* Motor with class F (105K) temperature rise.

Output		Frame	Full Load Torque (ft.lb)	Locked Rotor Current		Locked Rotor Torque Tl/Tn	Break-down Torque Tb/Tn	Inertia J (sq.ft.lb)	Allowable locked rotor time (s)		Weight (lb)	Sound dB(A)	Service Factor	460 V							Full load current In (A)
				Code	I/In				Hot	Cold				Rated speed (rpm)	% of full load			Power Factor			
															50	75	100	50	75	100	
VIII Poles																					
1	0,75	182/4T	5,92	M	6,0	3,0	3,5	0,3991	22	48	94,8	50,0	1,25	875	74,0	77,0	78,5	0,32	0,42	0,52	2,30
1,5	1,1	182/4T	8,98	K	5,9	2,9	3,4	0,5766	17	37	111	50,0	1,25	865	80,0	82,5	82,5	0,43	0,54	0,62	2,70
2	1,5	213/5T	11,8	M	7,6	2,4	2,9	1,79	39	86	149	52,0	1,25	875	82,5	84,0	85,5	0,45	0,55	0,65	3,39
3	2,2	213/5T	17,9	K	6,8	2,3	2,8	2,11	44	97	176	52,0	1,25	870	84,0	85,5	85,5	0,50	0,63	0,71	4,55
5	3,7	254/6T	29,4	H	5,3	1,9	2,5	3,41	44	97	258	54,0	1,25	880	85,5	87,5	87,5	0,49	0,62	0,70	7,58
7,5	5,5	254/6T	44,2	G	5,3	2,0	2,5	4,43	33	73	284	54,0	1,25	880	85,5	87,5	87,5	0,50	0,63	0,71	11,1
10	7,5	284/6T	58,9	G	5,6	2,0	2,4	7,20	32	70	373	54,0	1,25	880	89,5	90,2	90,2	0,61	0,72	0,78	13,4
15	11	284/6T	88,3	G	5,5	2,0	2,3	8,18	25	55	417	54,0	1,25	880	85,5	90,0	90,2	0,62	0,72	0,78	19,6
20	15	324T	118	G	5,0	1,9	2,2	9,37	27	59	452	56,0	1,25	880	89,5	91,0	91,0	0,54	0,66	0,73	28,3
20	15	324/6T	118	G	5,0	1,9	2,2	9,37	27	59	452	56,0	1,25	880	89,5	91,0	91,0	0,54	0,66	0,73	28,3
25	18,5	324/6T	147	G	5,2	2,0	2,3	11,9	23	51	509	56,0	1,25	880	89,5	91,0	91,0	0,51	0,64	0,71	35,9
30	22	364/5T	177	G	6,2	1,7	2,4	23,5	20	44	803	60,0	1,25	880	92,4	92,4	92,4	0,63	0,74	0,80	37,0
40	30	364/5T	234	G	5,9	1,7	2,3	29,0	18	40	875	60,0	1,25	885	92,4	93,0	92,4	0,63	0,74	0,78	52,2
50	37	404/5T	294	H	6,8	1,7	2,6	34,6	15	33	1012	60,0	1,25	880	93,0	93,0	93,0	0,68	0,78	0,83	60,0
60	45	404/5T	353	H	6,5	1,8	2,7	40,2	13	29	1111	60,0	1,25	880	93,0	93,0	93,0	0,68	0,78	0,83	73,0
75	55	444/5T	437	G	6,0	1,8	2,1	73,6	18	40	1444	63,0	1,25	890	93,0	93,6	93,6	0,64	0,74	0,79	93,0
100	75	444/5T	582	G	6,0	1,9	2,2	87,3	15	33	1599	63,0	1,25	890	93,6	94,1	94,1	0,63	0,74	0,79	127
125	90	445/7T	728	G	6,0	1,8	2,1	104	17	37	1887	63,0	1,15	890	94,5	94,5	94,5	0,64	0,74	0,79	151
150	110	445/7T	873	G	6,0	1,9	2,1	125	15	33	2042	63,0	1,15	890	94,5	94,5	94,5	0,64	0,74	0,79	185
200	150	586/7T	1158	G	6,3	1,4	2,1	350	40	88	3334	75,0	1,15	895	95,0	95,4	95,4	0,65	0,75	0,80	247
250	185	586/7T	1447	G	6,2	1,4	2,1	395	40	88	3649	75,0	1,15	895	95,4	95,8	95,8	0,66	0,76	0,81	299
300	220	586/7T	1737	H	6,7	1,5	2,2	451	40	88	4035	75,0	1,15	895	95,4	95,8	95,8	0,66	0,77	0,81	356
350	260	586/7T	2026	G	6,4	1,6	2,3	484	34	75	4309	75,0	1,00	895	95,4	95,8	95,8	0,64	0,75	0,80	426
400	300	588/9T	2315	H	6,7	1,5	2,4	537	25	55	4851	75,0	1,00	895	95,0	95,6	95,7	0,62	0,73	0,79	498
450	330	588/9T	2605	G	6,6	1,6	2,3	617	27	59	5281	75,0	1,00	895	95,2	95,7	95,8	0,65	0,75	0,81	534
High-Output Design																					
7,5	5,5	284T	44,2	G	5,6	2,0	2,4	7,20	34	75	344	54,0	1,25	880	87,5	88,5	88,5	0,60	0,72	0,78	10,0
100	75	447/9T	582	G	6,0	1,9	2,2	87,3	15	33	1599	66,0	1,25	890	93,6	94,1	94,1	0,63	0,74	0,79	127
125	90	504/5T	728	G	5,9	1,8	2,0	104	23	51	2110	66,0	1,15	890	94,5	94,5	94,5	0,66	0,76	0,80	149
150	110	504/5T	873	F	5,8	1,8	2,0	125	21	46	2293	66,0	1,15	890	94,5	94,5	94,5	0,68	0,77	0,81	180
150	110	504/5TS	873	F	5,8	1,8	2,0	125	21	46	2293	66,0	1,15	890	94,5	94,5	94,5	0,68	0,77	0,81	180
200	150	447/9T	1164	H	6,4	2,0	2,2	161	13	29	2509	66,0	1,15	890	94,5	95,0	95,0	0,62	0,73	0,78	254
250	185	L447/9T	1455	G	6,0	2,0	2,3	255	24	53	3550	64,0	1,15	890	95,4	95,4	95,4	0,65	0,75	0,79	308
300	220	L447/9T*	1746	G	6,3	2,2	2,4	285	16	35	3704	64,0	1,15	890	95,4	95,4	95,4	0,62	0,73	0,78	371

* Motor with class F (105K) temperature rise.

W22 - Super Premium Efficiency

Output		Frame	Full Load Torque (ft.lb)	Locked Rotor Current		Locked Rotor Torque Tl/Tn	Break-down Torque Tb/Tn	Inertia J (sq.ft.lb)	Allowable locked rotor time (s)		Weight (lb)	Sound dB(A)	Service Factor	460 V						Full load current In (A)	
				Code	I/In				Hot	Cold				Rated speed (rpm)	% of full load			Power Factor			
															50	75	100	50	75		100
II Poles																					
1	0,75	143/5T	1,49	J	7,2	2,5	3,0	0,0415	36	79	39,7	68,0	1,25	3485	81,5	82,5	84,0	0,69	0,79	0,83	1,35
1,5	1,1	143/5T	2,23	K	8,4	3,0	3,5	0,0470	29	64	41,9	68,0	1,25	3485	84,0	85,5	86,5	0,67	0,78	0,83	1,92
2	1,5	143/5T	2,97	K	8,2	3,2	3,6	0,0610	23	51	50,7	68,0	1,25	3490	85,5	87,5	87,5	0,69	0,80	0,84	2,56
3	2,2	182T	4,42	K	8,5	2,4	3,6	0,1920	50	110	88,2	69,0	1,25	3520	84,0	86,5	88,5	0,70	0,81	0,85	3,67
5	3,7	182/4T	7,39	J	8,2	2,4	3,5	0,2233	30	66	94,8	69,0	1,25	3505	87,5	88,5	90,2	0,73	0,83	0,86	5,99
7,5	5,5	213/5T	11,0	J	7,6	2,3	3,3	0,5548	37	81	141	72,0	1,25	3530	87,5	89,5	91,0	0,73	0,82	0,86	8,82
10	7,5	213/5T	14,7	J	8,0	2,4	3,2	0,7185	34	75	172	72,0	1,25	3535	89,5	91,0	91,7	0,77	0,85	0,89	11,5
15	11	254T	21,9	J	7,7	2,7	3,5	1,56	28	62	273	72,0	1,25	3545	90,2	91,7	92,4	0,72	0,82	0,86	17,4
20	15	254/6T	29,2	H	7,6	2,6	3,4	1,91	23	51	311	72,0	1,25	3545	91,0	92,4	93,0	0,75	0,84	0,88	23,0
25	18,5	284/6T	36,5	H	7,5	2,4	3,3	2,68	20	44	386	72,0	1,25	3550	91,7	93,0	93,6	0,75	0,83	0,87	28,5
30	22	286TS	43,8	H	7,5	2,4	3,3	3,19	19	42	437	72,0	1,25	3550	92,4	93,6	93,6	0,76	0,84	0,88	33,5
30	22	284/6T	43,8	H	7,5	2,4	3,3	3,19	19	42	437	72,0	1,25	3550	92,4	93,6	93,6	0,76	0,84	0,88	33,5
40	30	324/6TS	58,1	H	7,5	2,8	3,0	4,63	27	59	547	76,0	1,25	3565	92,4	94,1	94,1	0,74	0,83	0,86	46,5
50	37	324/6T	72,6	J	8,3	3,3	3,3	5,43	25	55	606	76,0	1,25	3570	93,0	94,5	94,5	0,74	0,83	0,86	57,1
60	45	364/5TS	87,1	H	7,9	2,4	3,2	8,61	25	55	926	79,0	1,25	3570	93,0	94,5	95,0	0,79	0,86	0,89	66,8
75	55	364/5TS	109	H	8,0	2,6	3,2	8,61	14	31	937	79,0	1,25	3570	93,6	95,0	95,0	0,77	0,85	0,88	82,6
100	75	404/5TS	145	H	8,0	2,9	3,2	14,3	20	44	1180	79,0	1,25	3565	94,5	95,4	95,4	0,81	0,87	0,89	111
125	90	444/5TS	181	J	8,2	2,3	3,1	31,3	44	97	1680	81,0	1,25	3580	94,1	95,4	95,8	0,76	0,84	0,87	136
150	110	444/5TS	217	H	7,9	2,6	3,2	38,5	30	66	1863	81,0	1,25	3580	94,5	95,8	96,2	0,77	0,85	0,88	163
200	150	445/7TS	290	H	7,3	2,4	2,9	41,6	28	62	2029	81,0	1,25	3575	95,4	96,2	96,2	0,83	0,88	0,90	217
250	185	445/7TS	362	H	7,9	2,2	3,0	46,7	23	51	2183	81,0	1,25	3575	95,8	96,5	96,5	0,82	0,88	0,90	267
High-Output Design																					
3	2,2	182/4T	4,42	K	8,5	2,4	3,6	0,1920	50	110	88,2	69,0	1,25	3520	84,0	86,5	88,5	0,70	0,81	0,85	3,67
15	11	254/6T	21,9	J	7,7	2,7	3,5	1,56	28	62	273	72,0	1,25	3545	90,2	91,7	92,4	0,72	0,82	0,86	17,4
25	18,5	284TS	36,5	H	7,5	2,4	3,3	2,68	20	44	386	72,0	1,25	3550	91,7	93,0	93,6	0,75	0,83	0,87	28,5
25	18,5	284/6TS	36,5	H	7,5	2,4	3,3	2,68	20	44	386	72,0	1,25	3550	91,7	93,0	93,6	0,75	0,83	0,87	28,5
30	22	284/6TS	43,8	H	7,5	2,4	3,3	3,19	19	42	437	72,0	1,25	3550	92,4	93,6	93,6	0,76	0,84	0,88	33,5
50	37	326TS	72,6	J	8,3	3,3	3,3	5,43	25	55	606	76,0	1,25	3570	93,0	94,5	94,5	0,74	0,83	0,86	57,1
50	37	324/6TS	72,6	J	8,3	3,3	3,3	5,43	25	55	606	76,0	1,25	3570	93,0	94,5	94,5	0,74	0,83	0,86	57,1
IV Poles																					
1	0,75	L143T	2,94	L	9,0	2,6	3,3	0,1554	33	73	50,7	51,0	1,25	1760	84,0	86,5	87,5	0,59	0,70	0,79	1,33
1,5	1,1	L143/5T	4,42	L	8,8	2,8	3,4	0,1815	20	44	55,1	51,0	1,25	1760	85,5	87,5	88,5	0,62	0,74	0,81	1,93
2	1,5	L143/5T	5,89	L	8,6	2,9	3,6	0,1815	14	31	57,3	51,0	1,25	1760	86,5	87,5	88,5	0,61	0,74	0,81	2,63
3	2,2	182/4T	8,81	K	8,3	2,3	3,2	0,3961	36	79	92,6	56,0	1,25	1765	87,5	88,5	91,0	0,63	0,75	0,81	3,75
5	3,7	L182/4T	14,8	J	7,5	2,3	3,1	0,4877	20	44	112	56,0	1,25	1755	88,5	90,2	91,0	0,61	0,73	0,80	6,38
7,5	5,5	L213T	22,0	K	8,5	2,3	3,5	1,51	20	44	172	58,0	1,25	1770	91,0	92,4	93,0	0,65	0,76	0,83	8,94
10	7,5	L213/5T	29,4	K	8,4	2,3	3,5	1,78	16	35	181	58,0	1,25	1765	91,7	92,4	93,0	0,66	0,78	0,84	12,0
15	11	254/6T	43,8	K	8,5	2,8	3,3	3,66	20	44	280	64,0	1,25	1775	91,7	93,0	93,6	0,66	0,76	0,83	17,8
20	15	254/6T	58,5	J	7,4	2,6	3,0	4,29	30	66	326	64,0	1,25	1770	93,0	93,6	94,1	0,63	0,75	0,81	24,7
25	18,5	284/6T	73,0	K	8,3	3,0	3,4	4,94	26	57	406	63,0	1,25	1775	93,0	94,1	94,5	0,62	0,74	0,81	30,3
30	22	284/6T	87,6	J	8,0	3,2	3,5	5,67	25	55	450	63,0	1,25	1775	93,0	94,1	94,5	0,64	0,76	0,82	35,6
40	30	324/6T	116	K	8,4	3,2	3,5	8,83	22	48	534	66,0	1,25	1780	93,6	94,5	95,0	0,64	0,75	0,81	48,9
50	37	324/6T	146	H	7,4	2,6	3,0	9,82	20	44	598	66,0	1,25	1780	94,1	95,0	95,4	0,62	0,73	0,81	60,1
60	45	364/5T	175	J	8,5	2,7	3,2	16,9	24	53	897	67,0	1,25	1780	94,5	95,4	95,8	0,69	0,80	0,84	70,2
75	55	364/5T	218	J	8,4	2,8	3,2	16,9	16	35	919	67,0	1,25	1780	94,5	95,4	95,8	0,68	0,78	0,83	86,8
100	75	404/5T	291	K	8,8	2,7	3,1	28,7	12	26	1188	68,0	1,25	1780	95,4	95,8	96,2	0,70	0,80	0,84	116
125	90	444/5T	363	J	8,2	2,4	3,0	58,4	38	84	1722	73,0	1,25	1785	95,0	95,8	96,2	0,68	0,79	0,84	140
150	110	444/5T	435	K	8,9	2,5	3,0	73,0	30	66	1951	73,0	1,25	1785	95,4	96,2	96,5	0,68	0,79	0,84	170
200	150	447/9T	580	J	7,7	2,8	3,0	98,7	24	53	2293	75,0	1,25	1785	95,8	96,5	96,8	0,66	0,77	0,83	234
250	185	447/9T	726	H	7,5	2,7	2,9	104	21	46	2536	75,0	1,25	1785	96,2	96,5	96,8	0,68	0,78	0,84	286

Output		Frame	Full Load Torque (ft.lb)	Locked Rotor Current		Locked Rotor Torque Tl/Tn	Break-down Torque Tb/Tn	Inertia J (sq.ft.lb)	Allowable locked rotor time (s)		Weight (lb)	Sound dB(A)	Service Factor	460 V						Full load current In (A)
				Code	II/In				Hot	Cold				% of full load			Power Factor			
														Rated speed (rpm)	50	75	100	50	75	

High-Output Design - IV Poles

1	0,75	143/5T	2,94	L	9,0	2,6	3,3	0,1554	33	73	50,7	51,0	1,25	1760	84,0	86,5	87,5	0,59	0,70	0,79	1,33
1	0,75	145T	2,94	L	9,0	2,6	3,3	0,1554	33	73	50,7	51,0	1,25	1760	84,0	86,5	87,5	0,59	0,70	0,79	1,33
3	2,2	L182T	8,81	K	8,3	2,3	3,2	0,3961	36	79	92,6	56,0	1,25	1765	87,5	88,5	91,0	0,63	0,75	0,81	3,75
7,5	5,5	213/5T	22,0	K	8,5	2,3	3,5	1,51	20	44	172	58,0	1,25	1770	91,0	92,4	93,0	0,65	0,76	0,83	8,94
25	18,5	284TS	73,0	K	8,3	3,0	3,4	4,94	26	57	406	63,0	1,25	1775	93,0	94,1	94,5	0,62	0,74	0,81	30,3
30	22	284/6TS	87,6	J	8,0	3,2	3,5	5,67	25	55	450	63,0	1,25	1775	93,0	94,1	94,5	0,64	0,76	0,82	35,6
40	30	324TS	116	K	8,4	3,2	3,5	8,83	22	48	534	66,0	1,25	1780	93,6	94,5	95,0	0,64	0,75	0,81	48,9
50	37	326TS	146	H	7,4	2,6	3,0	9,82	20	44	598	66,0	1,25	1780	94,1	95,0	95,4	0,62	0,73	0,81	60,1
60	45	364/5TS	175	J	8,5	2,7	3,2	16,9	24	53	897	67,0	1,25	1780	94,5	95,4	95,8	0,69	0,80	0,84	70,2
75	55	364/5TS	218	J	8,4	2,8	3,2	16,9	16	35	919	67,0	1,25	1780	94,5	95,4	95,8	0,68	0,78	0,83	86,8
100	75	404/5TS	291	K	8,8	2,7	3,1	28,7	12	26	1188	68,0	1,25	1780	95,4	95,8	96,2	0,70	0,80	0,84	116
125	90	444/5TS	363	J	8,2	2,4	3,0	58,4	38	84	1722	73,0	1,25	1785	95,0	95,8	96,2	0,68	0,79	0,84	140
150	110	444/5TS	435	K	8,9	2,5	3,0	73,0	30	66	1951	73,0	1,25	1785	95,4	96,2	96,5	0,68	0,79	0,84	170
200	150	447/9TS	580	J	7,7	2,8	3,0	98,7	24	53	2293	75,0	1,25	1785	95,8	96,5	96,8	0,66	0,77	0,83	234
250	185	447/9TS	726	H	7,5	2,7	2,9	104	21	46	2536	75,0	1,25	1785	96,2	96,5	96,8	0,68	0,78	0,84	286

VI Poles

3	2,2	213/5T	13,2	K	7,2	1,8	2,9	1,53	90	198	172	55,0	1,25	1175	87,5	89,5	90,2	0,51	0,63	0,71	4,31
5	3,7	L213/5T	22,1	J	7,0	1,9	2,5	1,80	70	154	198	55,0	1,25	1170	89,5	91,0	91,0	0,56	0,68	0,75	6,80
7,5	5,5	254/6T	33,1	H	6,8	2,5	3,1	4,57	50	110	304	59,0	1,25	1175	90,2	91,7	92,4	0,60	0,72	0,79	9,46
10	7,5	254/6T	43,9	H	6,8	2,4	3,0	5,40	40	88	344	59,0	1,25	1180	91,0	92,4	92,4	0,62	0,74	0,80	12,7
15	11	284/6T	65,9	H	7,1	2,6	3,0	7,69	25	55	410	59,0	1,25	1180	91,7	92,4	93,0	0,65	0,76	0,82	18,1
20	15	284/6T	87,8	J	7,4	2,7	3,0	9,29	20	44	474	59,0	1,25	1180	91,7	92,4	93,0	0,67	0,78	0,83	24,4
25	18,5	324/6T	109	J	7,3	2,6	3,1	11,2	30	66	527	62,0	1,25	1185	92,4	93,6	94,1	0,61	0,73	0,80	30,8
30	22	324/6T	131	H	7,0	2,6	3,0	12,9	27	59	584	62,0	1,25	1185	92,4	93,6	94,1	0,60	0,73	0,80	36,7
40	30	364/5T	174	K	8,4	2,6	3,2	24,2	22	48	875	66,0	1,25	1190	93,6	94,5	95,0	0,64	0,76	0,81	48,9
50	37	364/5T	218	K	8,5	2,6	3,3	25,0	12	26	895	66,0	1,25	1190	93,6	94,5	95,0	0,63	0,75	0,81	60,3
60	45	404/5T	262	J	7,9	2,8	3,2	39,1	22	48	1111	68,0	1,25	1185	94,1	95,0	95,4	0,65	0,77	0,82	72,2
75	55	404/5T	327	J	8,0	2,8	3,0	41,3	15	33	1125	68,0	1,25	1190	94,1	95,0	95,4	0,64	0,75	0,81	89,3
100	75	444/5T	435	J	7,6	2,6	3,2	106	27	59	1896	69,0	1,25	1190	94,5	95,4	95,8	0,60	0,72	0,79	124
125	93	444/5T	544	J	7,6	2,4	2,6	114	25	55	1945	69,0	1,25	1190	95,0	95,8	95,8	0,62	0,74	0,80	152
150	110	447/9T	653	J	7,5	2,6	3,2	145	22	48	2256	70,0	1,25	1190	95,0	95,8	96,2	0,62	0,74	0,80	179
200	150	447/9T	871	J	7,5	2,6	3,0	156	15	33	2326	70,0	1,25	1190	95,4	95,8	96,2	0,60	0,72	0,80	245
250	185	586/7T	1088	G	6,4	2,1	2,1	226	50	110	3638	77,0	1,25	1190	95,0	95,9	96,3	0,67	0,77	0,81	298

High-Output Design

3	2,2	L213T	13,2	K	7,2	1,8	2,9	1,53	90	198	172	55,0	1,25	1175	87,5	89,5	90,2	0,51	0,63	0,71	4,31
15	11	284TS	65,9	H	7,1	2,6	3,0	7,69	25	55	410	59,0	1,25	1180	91,7	92,4	93,0	0,65	0,76	0,82	18,1
20	15	284/6TS	87,8	J	7,4	2,7	3,0	9,29	20	44	474	59,0	1,25	1180	91,7	92,4	93,0	0,67	0,78	0,83	24,4
25	18,5	324TS	109	J	7,3	2,6	3,1	11,2	30	66	527	62,0	1,25	1185	92,4	93,6	94,1	0,61	0,73	0,80	30,8
30	22	326TS	131	H	7,0	2,6	3,0	12,9	27	59	584	62,0	1,25	1185	92,4	93,6	94,1	0,60	0,73	0,80	36,7
40	30	364/5TS	174	K	8,4	2,6	3,2	24,2	22	48	875	66,0	1,25	1190	93,6	94,5	95,0	0,64	0,76	0,81	48,9
50	37	364/5TS	218	K	8,5	2,6	3,3	25,0	12	26	895	66,0	1,25	1190	93,6	94,5	95,0	0,63	0,75	0,81	60,3
60	45	404/5TS	262	J	7,9	2,8	3,2	39,1	22	48	1111	68,0	1,25	1185	94,1	95,0	95,4	0,65	0,77	0,82	72,2
75	55	404/5TS	327	J	8,0	2,8	3,0	41,3	15	33	1125	68,0	1,25	1190	94,1	95,0	95,4	0,64	0,75	0,81	89,3
100	75	444/5TS	435	J	7,6	2,6	3,2	106	27	59	1896	69,0	1,25	1190	94,5	95,4	95,8	0,60	0,72	0,79	124
125	93	444/5TS	544	J	7,6	2,4	2,6	114	25	55	1945	69,0	1,25	1190	95,0	95,8	95,8	0,62	0,74	0,80	152
150	110	447/9TS	653	J	7,5	2,6	3,2	145	22	48	2256	70,0	1,25	1190	95,0	95,8	96,2	0,62	0,74	0,80	179
200	150	447/9TS	871	J	7,5	2,6	3,0	156	15	33	2326	70,0	1,25	1190	95,4	95,8	96,2	0,60	0,72	0,80	245

15. Mechanical Data

Frames 143T to 215T

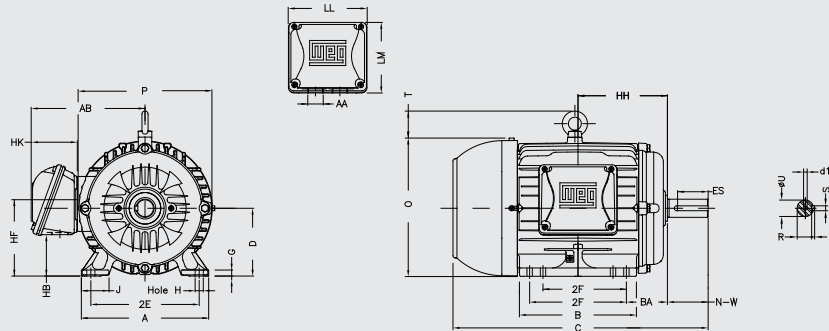

Frames 254T to 326T

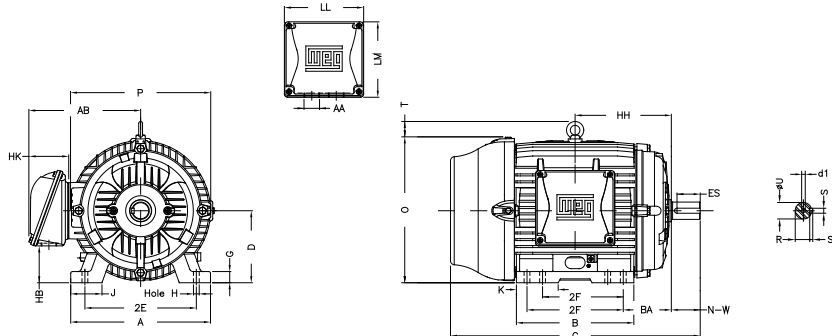

Frames 364 to 444/5T

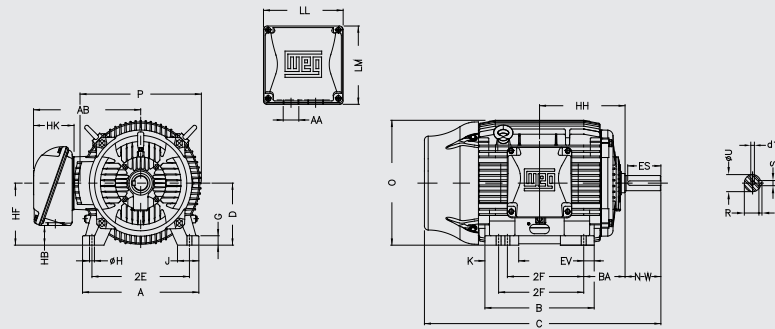

Frames 445/7T to 586/7T

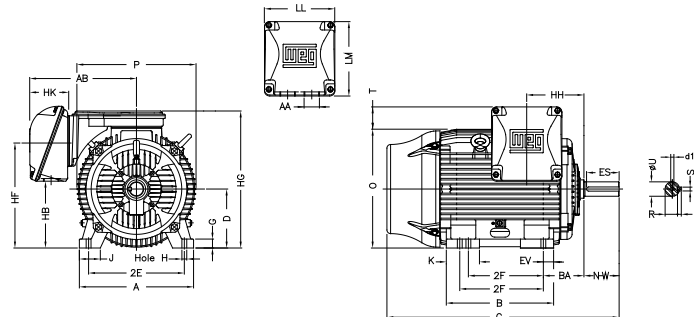

Frame 588/9T

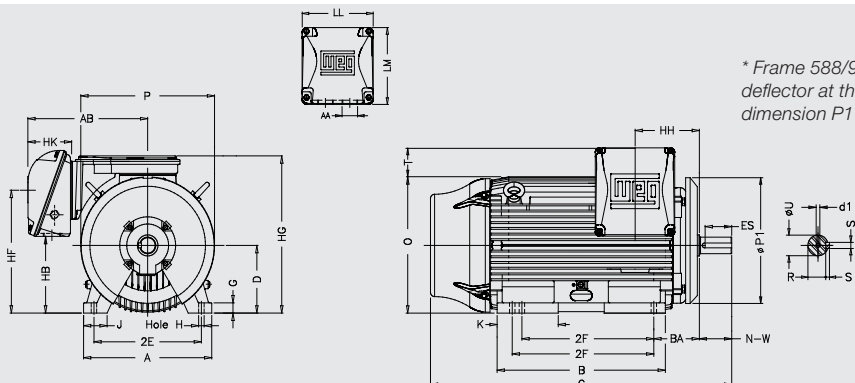

* Frame 588/9T is equipped with an air deflector at the DE. In this case the dimension P1 is 34.650"

Frame	Mounting				A	B	C	D	G	J	O	K	P	T	Keyway											
	2E	2F	H	BA											S	R	ES									
143T	5.500	4.000	0.340	2.250	6.457	5.157	12.346	3.500	0.354	1.457	7.122	7.244	-	0.187	0.771	1.575										
L143T							13.566																			
143/5T		4.000/5.000				6.142	13.358																			
L143/5T							14.520																			
145T						5.000	13.358																			
L145T	14.520																									
182T	7.500	4.500	0.410	2.750	8.661	5.945	14.860	4.500	0.394	1.614	8.897	8.937	2.218	0.250	0.984	1.969										
L182T							16.014																			
182/4T		4.500/5.500				6.969	15.860																			
L182/4T							17.014																			
184T						5.500	15.860																			
L184T	17.014																									
213T	8.500	5.500/7.000	0.410	3.500	9.764	7.362	18.021	5.250	0.669	1.791	10.840	2.165	10.787	1.773	0.313	1.203	2.480									
L213T							19.083																			
213/5T		5.500/7.000				8.858	19.517																			
L213/5T							20.446																			
215T						7.000	19.517																			
L215T	20.446																									
254T	10.000	8.252	0.531	4.250	11.496	10.000	23.213	6.250	1.787	12.598	2.559	12.953	2.313	0.375	1.416	2.756										
254/6T		8.252/10.000				11.732	24.945																			
256T		10.000					24.945																			
284T		9.500				11.575	26.433																			
L284T							25.061																			
284/6T	9.500/11.000	13.071	27.929																							
L284/6T			26.557																							
286T		11.000	13.071	27.929																						
L286T	26.557																									
324T	12.500	10.500	0.657	5.250	15.157	14.567	29.620	8.000	1.300	3.189	15.953	4.055	15.827	2.441	0.500	1.844	3.937									
L324T							28.120									1.844	3.937									
324/6T		10.500/12.000				14.567	31.116																			
L324/6T							29.616									1.844	3.937									
326T						12.000	31.116									1.844	3.937									
L326T	29.616	1.844	3.937																							
364/5T	14.016	11.260/12.244	0.660	5.875	17.165	15.512	34.251	9.000	1.480	3.150	17.957	4.138	17.914	-	0.625	2.019	4.330									
L364/5T							32.338								0.500	1.591	1.968									
404/5T		12.244/13.740				6.625	19.921								18.386	20.315	39.730	10.000	1.811	19.566	5.669	19.134	-	0.750	2.449	5.512
L404/5T																										
444/5T						14.500/16.500	0.810								7.500	21.929	23.897	45.157	1.630	3.937	22.795	5.866	23.583	4.732	0.875	2.880
L444/5T	41.407	0.625	2.021	3.000																						
445/7T	16.500/20.000	0.810	7.500	21.929	31.535	48.779	1.630	11.000	1.654	3.937	22.795	7.244	23.583	0.875	2.880	7.087										
L445/7T						44.951								0.625	2.021	3.000										
447/9T						20.000/25.000								0.810	7.500	21.929	31.535	56.338	1.630	11.000	1.630	3.937	22.795	11.772	4.732	0.875
L447/9T	52.588	0.625	2.021	3.000																						
447/9T	20.000/25.000	0.810	7.500	21.929	31.535	57.181	1.630	11.000	1.630	3.937	22.795	11.772	4.732	0.625	2.021	3.000										
L447/9T						53.431								0.875	2.880	7.087										
504/5T						16.000/18.000								1.250	8.500	24.724	24.449	54.095	12.500	1.870	4.724	25.425	7.228	25.866	4.781	0.625
L504/5T	48.215	0.875	3.134	8.661																						
586/7T	22.000/25.000	1.181	10.000	29.528	29.921	61.902	14.500	2.492	5.512	9.055	28.977	8.884	6.755	1.000	3.312	8.661										
L586/7T						55.027								0.625	2.021	3.000										
588/9T	28.000/32.000	1.181	10.000	29.528	37.980	69.381	14.500	2.492	5.315	28.985	13.030	28.977	8.884	1.000	3.312	8.661										
L588/9T						62.506								0.625	2.021	3.000										

Frame	Terminal box									d1	Bearings		Shaft Extension			
	AB	HB	HF	HG	HH	HK	LL	LM	AA		DE	NDE	N-W	U		
143T / L143T	6.260	1.787	3.500	-	4.250	2.638	4.528	4.094	NPT 3/4"	A3,15	6205 ZZ	6204 ZZ	2.250	0.875		
143/5T / L143/5T					4.750											
145T / L145T					4.750											
182T / L182T	7.565	2.236	4.500	-	5.000	3.150	5.512	5.236	NPT 1"	A4	6207 ZZ	6206 ZZ	2.750	1.125		
182/4T / L182/4T					6.250											
184T / L184T					6.250											
213T / L213T	8.606	2.985	5.250	-	7.000	3.150	5.512	5.236	NPT 1"	A4	6308 ZZ	6207 ZZ	3.375	1.375		
213/5T / L213/5T					8.376											
215T / L215T					9.250											
254T	10.483	3.061	6.565	-	9.500	3.976	7.815	7.480	NPT 1 1/2"	A4	6309 C3	6209 C3	4.000	1.625		
254/6T					10.250										4.622	1.875
256T					10.250											
284T	11.073	3.535	7.000	-	10.250	3.976	7.815	7.480	NPT 1 1/2"	A4	6311 C3	6211 C3	4.622	1.875		
L284T													3.250	1.625		
284/6T													3.250	1.625		
284/6T	11.073	3.535	7.000	-	10.250	3.976	7.815	7.480	NPT 1 1/2"	A4	6311 C3	6211 C3	4.622	1.875		
L284/6T													3.250	1.625		
286T													3.250	1.625		
286T	11.073	3.535	7.000	-	10.250	3.976	7.815	7.480	NPT 1 1/2"	A4	6311 C3	6211 C3	4.622	1.875		
L286T													3.250	1.625		
324T													3.250	1.625		
324T	12.575	4.811	8.708	-	10.500	4.705	9.055	8.661	NPT 2"	A4	6312 C3	6212 C3	5.250	2.125		
L324T													3.750	1.875		
324/6T													3.750	1.875		
324/6T	12.575	4.811	8.708	-	11.250	4.705	9.055	8.661	NPT 2"	A4	6312 C3	6212 C3	5.250	2.125		
L324/6T													3.750	1.875		
326T													3.750	1.875		
326T	12.575	4.811	8.708	-	11.250	4.705	9.055	8.661	NPT 2"	A4	6312 C3	6212 C3	5.250	2.125		
L326T													3.750	1.875		
326TS													3.750	1.875		
364/5T	16.016	4.251	-	-	11.988	6.023	10.591	11.267	NPT 3"	A4	6314 C3	6314 C3	5.874	2.375		
L364/5T		5.252											3.748	1.875		
404/5T		5.252											3.748	1.875		
404/5T	18.570	5.687	-	-	13.496	5.970	12.362	12.283	NPT 3"	A4	6314 C3	6314 C3	7.250	2.875		
L404/5T													4.250	2.125		
444/5T													4.250	2.125		
444/5T	18.570	5.687	-	-	15.748	5.970	12.362	12.283	2xNPT 3"	DUNC 3/4"-10	6319 C3	6316 C3	8.500	3.375		
L444/5T											6314 C3	6314 C3	4.750	2.375		
445/7T											6319 C3	6316 C3	8.500	3.375		
445/7T	20.559	12.488	20.724	26.830	11.811	6.929	14.921	15.039	2xNPT 3"	DUNC 3/4"-10	6319 C3	6316 C3	8.500	3.375		
L445/7T											6314 C3	6314 C3	4.750	2.375		
447/9T											6322 C3	6319 C3	8.500	3.375		
447/9T	23.720	11.535	20.551	28.185	11.870	8.661	15.906	17.165	2xNPT 3"	DUNC 3/4"-10	6314 C3	6314 C3	4.750	2.375		
L447/9T											6314 C3	6314 C3	4.750	2.375		
504/5T											6319 C3	6316 C3	10.630	3.625		
504/5T	20.599	15.167	24.291	29.502	10.374	6.929	14.921	15.039	2xNPT 3"	DUNC 7/8"-9	6314 C3	6314 C3	4.750	2.375		
L504/5T											6322 C3	6319 C3	11.625	3.875		
586/7T											6314 C3	6314 C3	4.750	2.375		
586/7T	23.189	18.575	26.732	35.236	13.346	8.661	15.906	17.165	2xNPT 4"	DUNC 7/8"-9	6322 C3	6319 C3	11.625	3.875		
L586/7T											6314 C3	6314 C3	4.750	2.375		
588/9T											6322 C3	6319 C3	11.625	3.875		
588/9T	27.440	16.452	26.182	35.236	13.346	12.906	18.110	21.417	2xNPT 4"	DUNC 3/4"-10	6314 C3	6314 C3	4.750	2.375		
L588/9T											6314 C3	6314 C3	4.750	2.375		

Flange Mounted Motors

“D” Flange

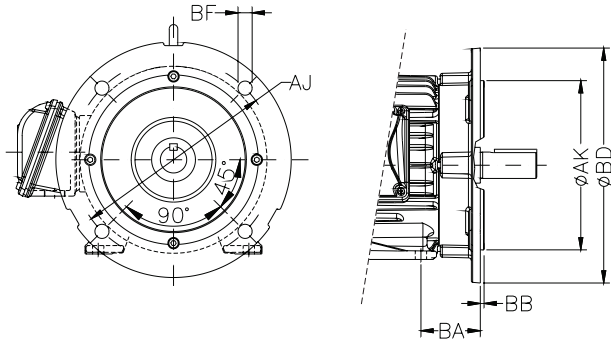

Frame	Flange	BA	BB	AK	BD	AJ	BF									
							Tap size	Quantity								
143/5TD	D-254	2.250	0.197	9.000	11.000	10.000	0.551	4								
182/4TD		2.750														
213/5TD		3.500														
254/6TD	D-317	4.250	0.203	11.000	14.000	12.500	0.828									
284/6TD		4.750														
284/6TSD		5.250														
324/6TD	D-406	5.250	0.197	14.000	18.000	16.000	0.828									
324/6TSD		5.250														
364/5TD		5.250														
364/5TSD	D-508	7.500	0.203	18.000	21.650	20.000	0.828									
404/5TD									0.203	22.000	20.000					
404/5TSD												0.197	21.650	20.000		
444/5TD								0.203							21.650	20.000
444/5TSD																
445/7TD									0.203	21.650	20.000					
445/7TSD												0.203	21.650	20.000		
447/9TD								0.203							21.650	20.000
447/9TSD	0.203	21.650	20.000													
504/5TD				D-558	8.500	0.250	24.800		22.000	0.828						
504/5TSD																
586/7TD				D-762	10.000	0.250	28.000	32.000	30.000	0.828						
586/7TSD																
588/9TD																
588/9TSD																

“C” Flange

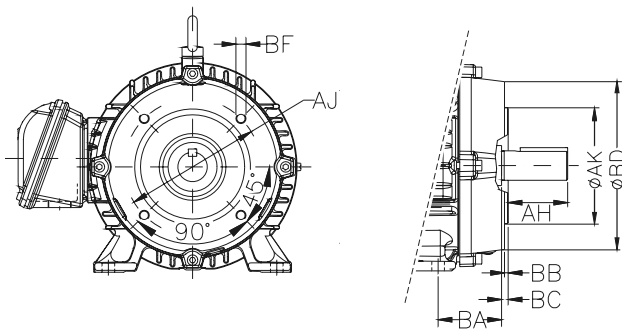

Frame	Flange	BA	BB	BC	AK	BD	AH	AJ	BF								
									Tap size	Quantity							
143/5TC	FC-149	2.250	0.157	0.125	4.500	6.496	2.125	5.875	UNC 3/8"x16	4							
182/4TC		2.750															
213/5TC		3.500															
254/6TC	FC-184	4.250	0.157	0.125	8.500	8.858	3.125	7.250	UNC 1/2"x13								
284/6TC		4.750															
284/6TSC		5.250															
324/6TC	FC-228	5.250	0.250	0.250	10.500	11.03	4.375	9.000	UNC 1/2"x13								
324/6TSC		5.250															
364/5TC		5.250															
364/5TSC	FC-279	6.625	0.250	0.250	12.500	13.580	5.000	11.000	UNC 1/2"x13								
404/5TC											0.250	15.55	4.000	7.000	4.000		
404/5TSC																16.000	17.913
444/5TC	16.000	17.913	8.250	4.500													
444/5TSC					16.000	17.913	8.250	4.500									
445/7TC									16.000	17.913	8.250	4.500					
445/7TSC													16.000	17.913	8.250	4.500	
447/9TC	16.000	17.913	8.250	4.500													
447/9TSC					16.000	17.913	8.250	4.500									
504/5TC									FC-355	7.500	0.250	0.250					16.000
504/5TSC																	
586/7TC	FC-368	8.500	0.250	0.250					16.500	17.91	11.375	14.500	UNC 5/8"x11				
586/7TSC					16.500	17.91	11.375	4.500									
588/9TC														16.500	17.91	11.375	4.500
588/9TSC																	

16. Terminal Box Drawing

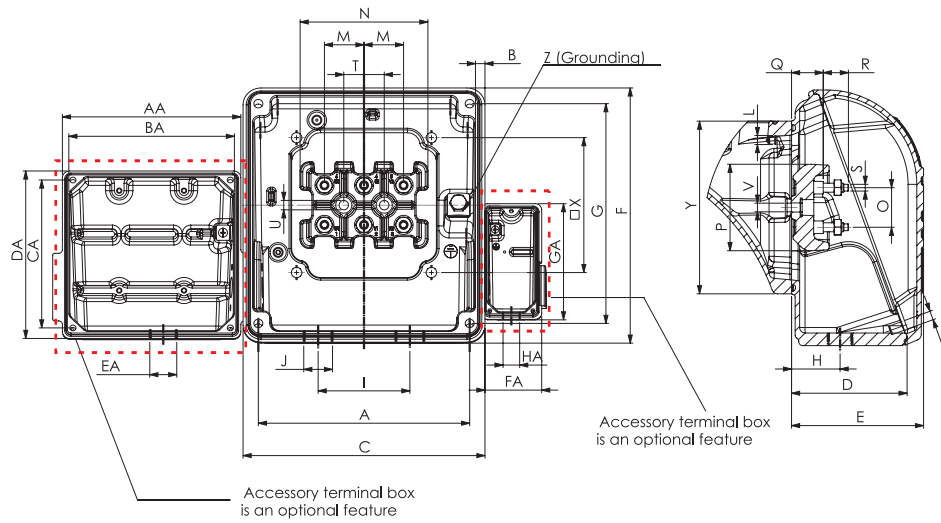

Frames	A	B	C	D	E	F	G	H	I	J	K	L	M	N	O	P	Q	R	S	T	U												
143/5T	3.858	0.276	4.528	2.283	2.638	4.094	3.583	1.220	1.654	NPT 3/4"	M5x0.8	M5x0.8	0.630	2.087	0.630	1.378	0.610	0.472	M4x0.7	0.787	0.228												
182/4T	4.606		5.512	2.717	3.150	5.236	4.606	1.417	2.126	NPT 1"	M6x1.0	M6x1.0	0.906	2.953	0.906	2.047	0.669	0.630	M5x0.8	0.906	0.256												
213/5T	4.606		5.512	2.717	3.150	5.236	4.606	1.417	2.126	NPT 1"	M6x1.0	M6x1.0	0.906	2.953	0.906	2.047	0.669	0.630	M5x0.8	0.906	0.256												
254/6T	6.890	0.335	7.815	3.386	3.976	7.480	6.890	1.811	3.307	NPT 1 1/2"	M8x1.25	M8x1.25	1.102	3.543	1.102	2.362	0.846	0.807	M6x1.0	1.102	0.260												
284/6T	6.890	0.335	7.815	3.386	3.976	7.480	6.890	1.811	3.307	NPT 1 1/2"			M8x1.25	M8x1.25	1.378	4.409	1.378	2.913	0.945	0.945	M8x1.25	1.378	0.374										
324/6T	8.031	0.374	9.055	3.996	4.705	8.661	8.031	2.205	3.701	NPT 2"	M10x1.5	M10x1.5	1.732	5.512	1.732	3.701	1.280	1.102	M10x1.5	1.772	0.413												
364/5T	9.252	0.492	10.591	5.000	6.024	11.267	10.236	2.677	4.331	NPT 3"												M10x1.5	M10x1.5	1.732	5.512	1.732	3.701	1.280	1.102	M10x1.5	1.772	0.413	
404/5T	9.252	0.492	10.591	5.000	6.024	11.267	10.236	2.677	4.331	NPT 3"												M10x1.5	M10x1.5	1.732	5.512	1.732	3.701	1.280	1.102	M10x1.5	1.772	0.413	
444/5T	10.827	0.531	12.362	5.118	5.970	12.283	10.827	4.961	6.299	2xNPT 3"	M12x1.75	M12x1.75	1.772	6.024	1.772	4.252	1.398	1.575	M12x1.75	1.772	0.413												
445/7T	13.386	0.571	14.921	6.142	6.929	15.039	13.583	3.228	6.299													2xNPT 3"	M12x1.75	M12x1.75	1.772	6.024	1.772	4.252	1.398	1.575	M12x1.75	1.772	0.413
447/9T	13.386	0.571	14.921	6.142	6.929	15.039	13.583	3.228	6.299													2xNPT 3"	M12x1.75	M12x1.75	1.772	6.024	1.772	4.252	1.398	1.575	M12x1.75	1.772	0.413
504/5T	13.386	0.571	14.921	6.142	6.929	15.039	13.583	3.228	6.299	2xNPT 3"	M12x1.75	M12x1.75	1.772	6.024	1.772	4.252	1.398	1.575	M12x1.75	1.772	0.413												
L447/9T	14.370	0.571	15.906	7.697	8.661	17.165	15.354	3.819	7.874	2xNPT 3"	M14x2.0	M14x2.0	2.559	8.268	2.559	5.748	2.008	1.772	M16x2.0	2.559	-												
586/7T	14.370	0.571	15.906	7.697	8.661	17.165	15.354	3.819	7.874				2xNPT 3"	M14x2.0	M14x2.0	2.559	8.268	2.559	5.748	2.008	1.772	M16x2.0	2.559	-									
588/9T	16.339	-	18.110	9.843	11.417	21.417	18.898	5.000	6.299	2xNPT 4"	M10x1.5	M10x1.5	3.150	-	4.134	-	-	-	-	M20x2.5	-	-											

Frames	V	X	Y	Z	AA	BA	CA	DA	EA	FA	GA	HA	Maximum connector number			Volume (in ³)						
													Main	Accessories	Space heater							
143/5T	M5x0.8	2.205	3.031	0.5-6 mm ²	4.291	3.543	3.346	3.858	-	-	-	-	4	16	-	25						
182/4T		2.756	4.213	2-10 mm ²									6				50					
213/5T		2.756	4.213	2-10 mm ²									6				50					
254/6T	M6x1.0	4.331	5.669	5.2-25 mm ²	4.291	3.543	3.346	3.858	-	-	4.016	-	-	-	-	135						
284/6T			5.512														5.2-25 mm ²	4.016	135			
324/6T	M8x1.25	4.724	6.102	5.2-35 mm ²	5.472	4.606	4.606	5.236	NPT 3/4"	2.657	-	NPT 3/4"	15	26	4	210						
364/5T	M10x1.5	5.906	7.559	25-50 mm ²													2.657	4.016	15	26	4	460
404/5T			7.559	25-50 mm ²													2.657	4.016	15	26	4	592
444/5T			7.559	25-50 mm ²	2.657	4.016	15	26	4	592												
445/7T	M10x1.5	7.874	10.236	35-70 mm ²	5.472	4.606	4.606	5.236	NPT 3/4"	2.657	5.236	NPT 3/4"	15	26	4	1100						
447/9T				35-70 mm ²													2.657	4.016	15	26	4	1696
504/5T				35-70 mm ²													2.657	4.016	15	26	4	1696
L447/9T	4xM6x1.5	11.417	12.008	85-120 mm ²	5.472	4.606	4.606	5.236	NPT 3/4"	2.657	5.236	NPT 3/4"	15	26	4	1696						
586/7T																	85-120 mm ²	2.657	4.016	15	26	4
588/9T	4xM6x1.5	11.417	12.008	85-120 mm ²	5.472	4.606	4.606	5.236	NPT 3/4"	2.657	5.236	NPT 3/4"	15	26	4	3300						

Note: terminal block is optional on NEMA motors.

17. Drip Cover Data

Utilization of a rain drip cover increases the total length of the motor. The additional land length can be seen in the table 20.

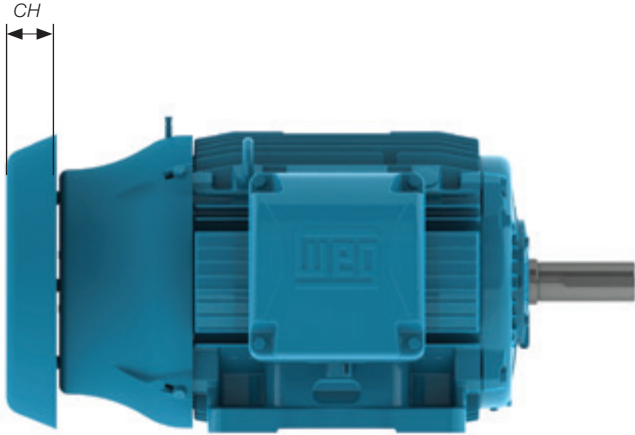

Figure 28 - Motor with drip cover.

Frame	Dimension CH [increase motor length (inches)]
143/5T	0.719
182/4T	1.337
213/5T	1.378
254/6T	1.850
284/6T	2.244
324/6T	2.638
364/5T	3.189
404/5T	
444/5T	3.583
445/7T	
447/9T	
504/5T	
586/7T	3.583
588/9T	

Table 20 - Increasing the total length of the motor with drip cover.

18. Distance From Fan Cover to Wall

See in the table 21 the distance from fan cover to wall.

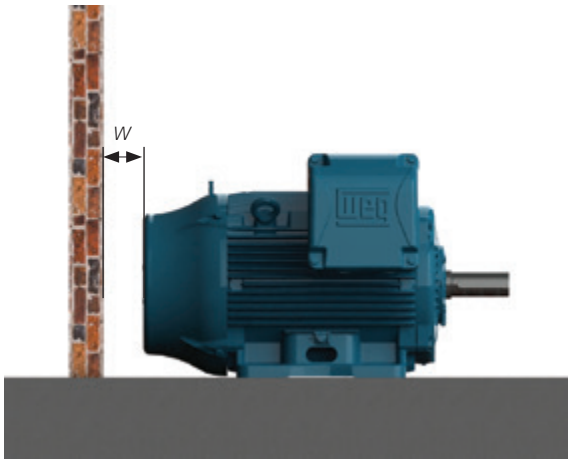

Figure 29 - Distance from fan cover to wall.

Frame	W - Distance from fan cover to wall [in]
143/5	1.30
182/4	1.61
213/5	1.98
254/6	2.56
284/6	2.66
324/6	3.08
364/5	3.35
404/5	
444/5	4.23
445/7	
447/9	
L447/9	4.80
504/5	
586/7	5.35
588/9	

Table 21 - Distance from fan cover to wall.

19. Packaging

19.1 Frames 143T to 215T

W22 motors in frames 143T to 215T are packaged in cardboard boxes (see figure 30), following the dimensions, weights and volumes of the tables 22 and 23.



Figure 30 - Cardboard box.

19.2 Frames 254T to 588/9T

For frames 254T to 588/9T, the motors are packaged in wooden crates (see figure 31). Dimensions, weights and volumes are in tables 24 and 25.



Figure 31 - Wooden crates.

Frame	External height (in)	External width (in)	External length (in)	Weight (lbf)	Volume (ft ³)
143T	12.598	10.630	17.008	2.0	1.3
145T	12.598	10.630	17.008	2.0	1.3
213T	16.535	12.992	23.425	3.7	2.9
215T	16.535	12.992	23.425	3.7	2.9

*F-3 mounting not available for frames 182 and 184.

Table 22 - Cardboard box dimensions, weights and volumes for top mounting.

Frame	External height (in)	External width (in)	External length (in)	Weight (lbf)	Volume (ft ³)
143T	9.252	12.402	15.669	1.8	1.0
145T	9.252	12.402	15.669	1.8	1.0
182T	11.811	14.961	18.307	2.6	1.9
184T	11.811	14.961	18.307	2.6	1.9
213T	13.780	16.535	23.425	4.5	3.1
215T	13.780	16.535	23.425	4.5	3.1

Table 23 - Cardboard box dimensions, weights and volumes for side mounting.

Frame	External height (in)	External width (in)	External length (in)	Weight (lbf)	Volume (ft ³)
254T	19.764	15.827	29.134	20.2	5.3
256T	19.764	15.827	29.134	20.2	5.3
284T	20.945	17.008	32.283	27.0	6.7
286T	20.945	17.008	32.283	27.0	6.7
324T	23.307	20.157	34.646	29.7	9.4
326T	23.307	20.157	34.646	29.7	9.4
364/5T	35.433	33.465	45.276	114.4	31.1
404/5T	35.433	33.465	49.213	120.3	33.8
444/5T	44.488	33.465	55.118	149.7	47.5
445/7T	44.488	33.465	62.992	177.7	54.3
447/9T	44.488	33.465	66.929	182.3	57.7
L447/9T	44.488	33.465	66.929	182.3	57.7
504/5T	44.488	33.465	61.024	154.1	52.6
586/7T	52.874	41.339	71.654	284.4	90.6
588/9T	56.063	50.787	80.709	427.7	133.0

Table 24 - Wooden crates dimensions, weights and volumes for top mounting.

Frame	External height (in)	External width (in)	External length (in)	Weight (lbf)	Volume (ft ³)
254T	15.827	20.157	29.134	21.7	5.4
256T	15.827	20.157	29.134	21.7	5.4
284T	17.795	22.520	32.283	29.6	7.5
286T	17.795	22.520	32.283	29.6	7.5
324T	19.370	24.882	34.646	32.1	9.7
326T	19.370	24.882	34.646	32.1	9.7
364/5T	31.496	33.465	45.276	109.6	27.6
404/5T	35.433	33.465	49.213	115.1	33.8
444/5T	37.402	37.402	55.118	157.9	44.6
445/7T	37.402	43.307	62.992	172.8	59.0
447/9T	37.402	43.307	66.929	188.1	62.7
L447/9T	37.402	43.307	66.929	188.1	62.7
504/5T	44.488	43.307	62.992	204.8	70.2
586/7T	44.488	46.850	71.654	324.1	86.4
588/9T	46.220	50.866	80.709	403.4	109.8

Note: values to be added to the net motor weight.

Table 25 - Wooden crates dimensions, weights and volumes for side mounting.

20. Spare Parts

Frames 143T to 184T

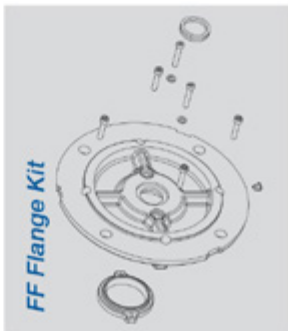
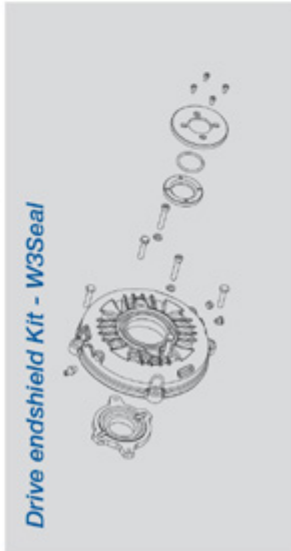
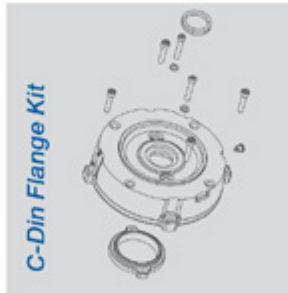
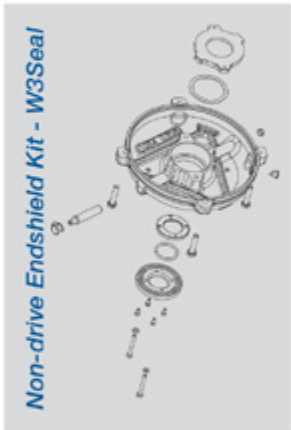
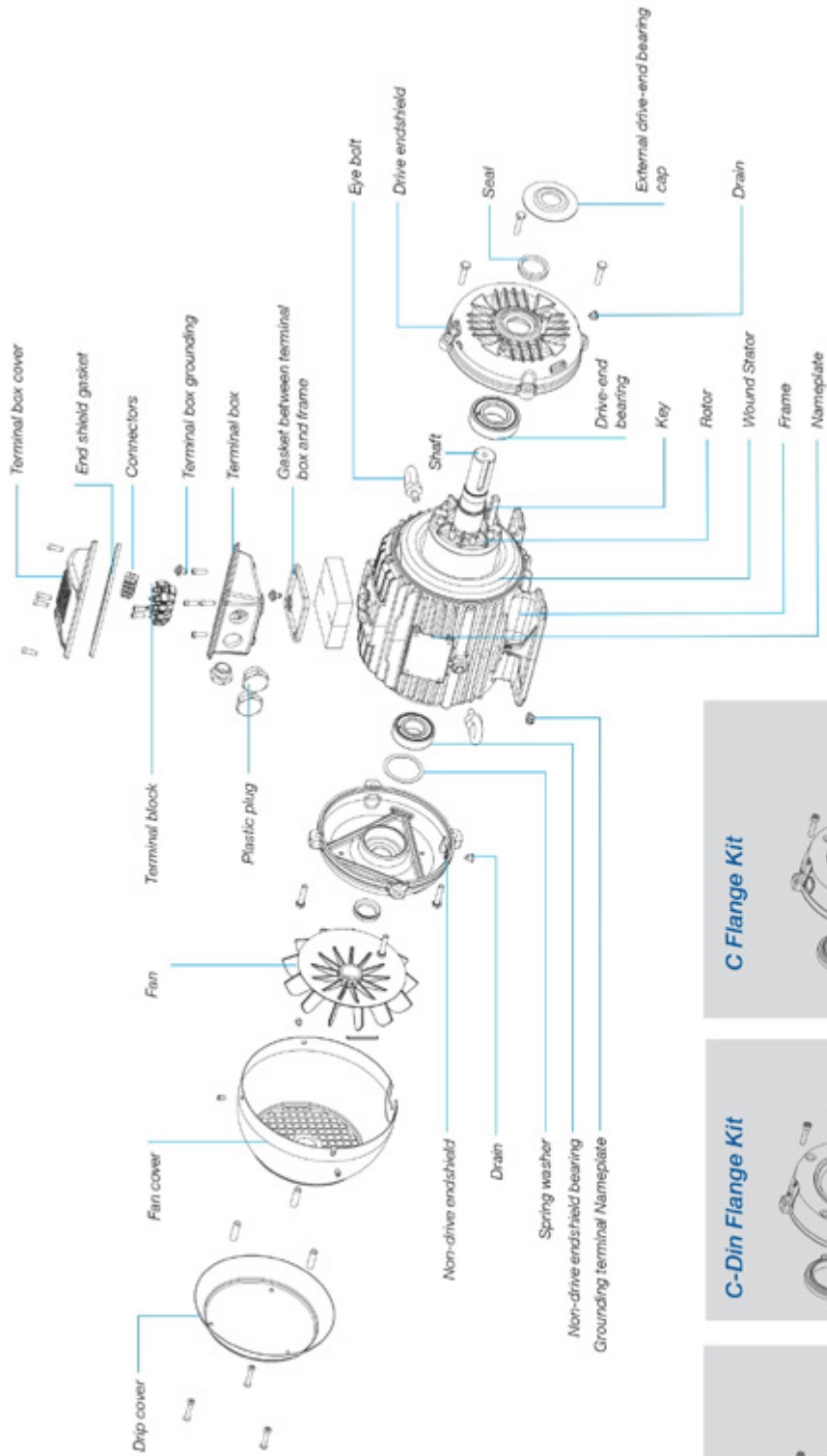

Frames 213T to 326T

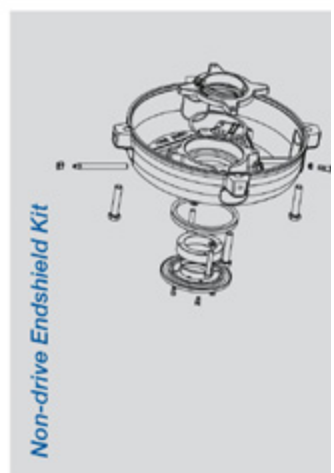
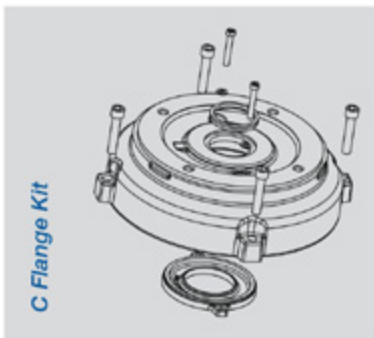
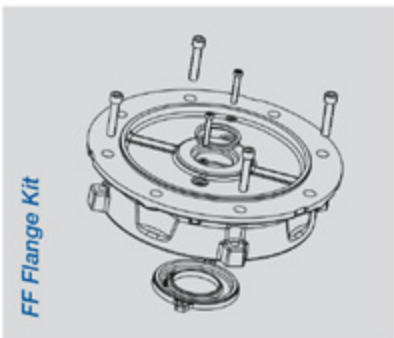
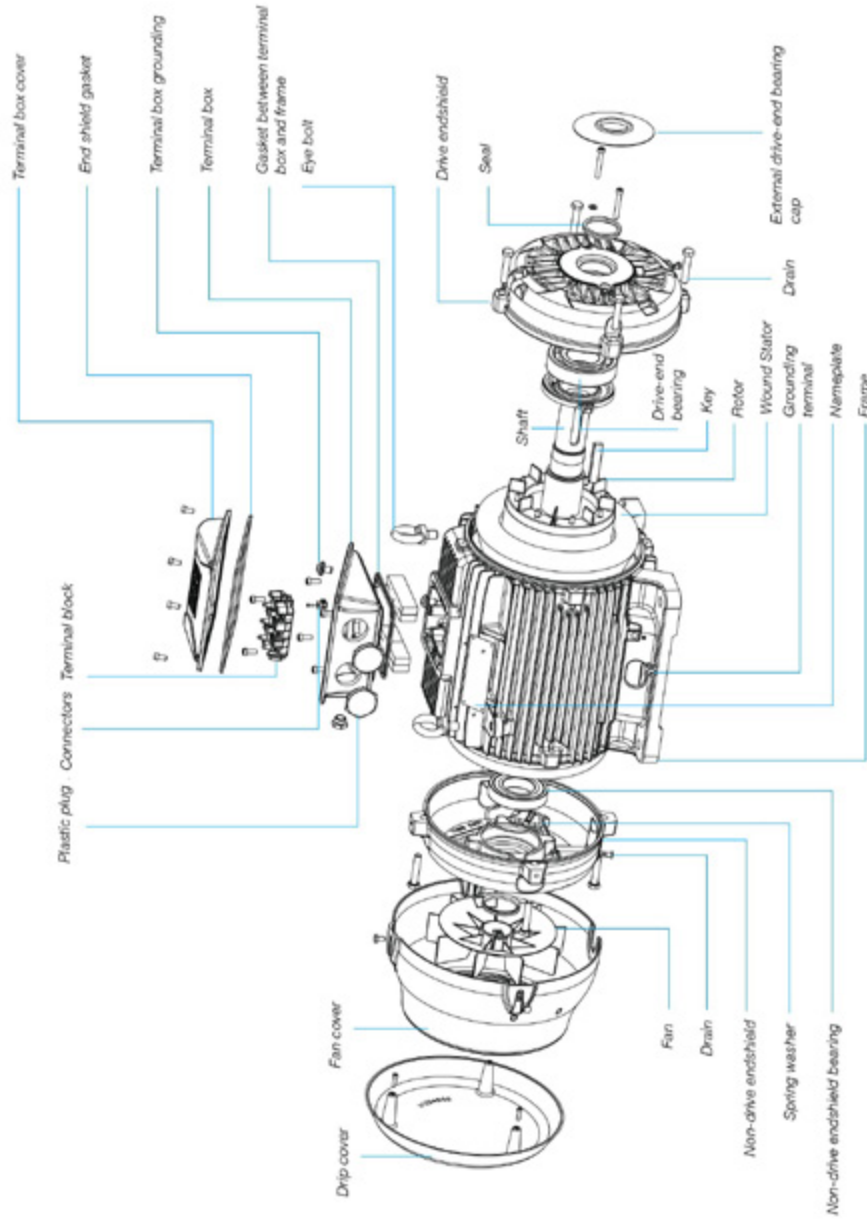

Frames 364/5T to 588/9T

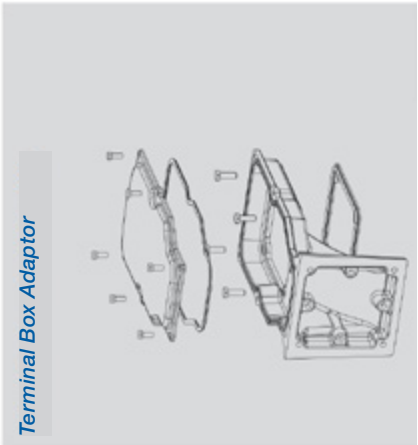
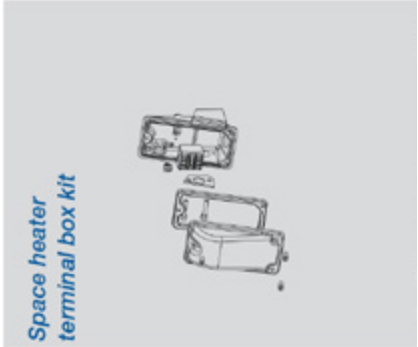
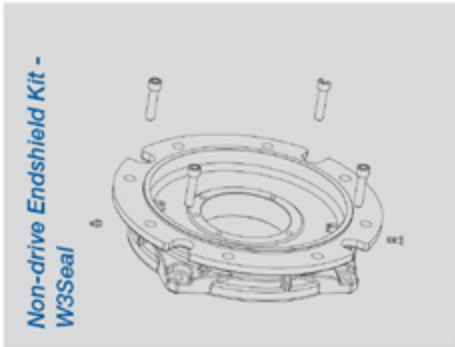
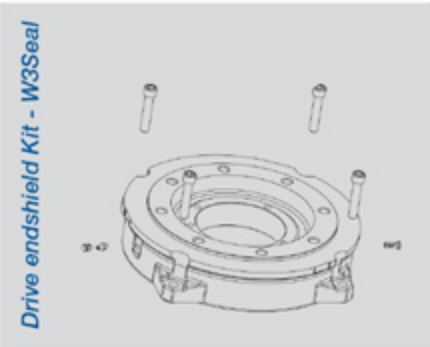
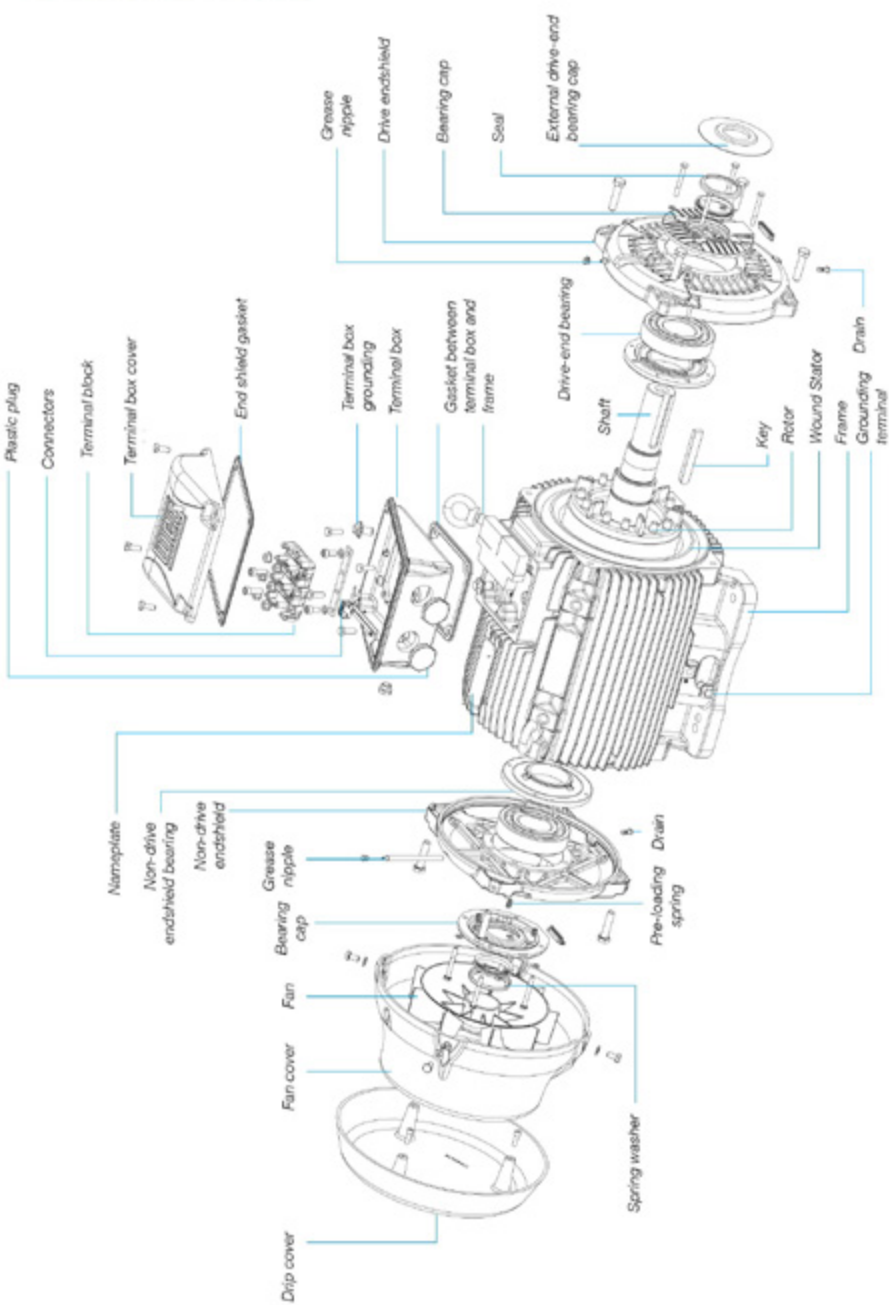

WEG Worldwide Operations

ARGENTINA

San Francisco - Cordoba
Phone: +54 3564 421484
info-ar@weg.net

Cordoba - Cordoba
Phone: +54 3514 641366
weg-morbe@weg.com.ar

Buenos Aires
Phone: +54 1142 998000
ventas@pulverlux.com.ar

AUSTRALIA

Scoresby - Victoria
Phone: +61 3 97654600
info-au@weg.net

AUSTRIA

Markt Piesting - Wiener
Neustadt-Land
Phone: +43 2 633 4040
watt@wattdrive.com

Vienna
Phone: +43 1 796 2048
wtr@weg.net

BELGIUM

Nivelles - Belgium
Phone: +32 67 888420
info-be@weg.net

BRAZIL

Jaraguá do Sul - Santa Catarina
Phone: +55 47 32764000
info-br@weg.net

CHILE

Santiago
Phone: +56 2 27848900
info-cl@weg.net

CHINA

Nantong - Jiangsu
Phone: +86 513 85989333
info-cn@weg.net

Changzhou - Jiangsu
Phone: +86 519 88067692
info-cn@weg.net

Rugao - Jiangsu
Phone: +86 513 80672011
zhuhua@weg.net

COLOMBIA

San Cayetano - Bogota
Phone: +57 1 4160166
info-co@weg.net

Sabaneta - Antioquia
Phone: +57 4 4449277
info-co@weg.net

ECUADOR

El Batan - Quito
Phone: +593 2 5144339
wegecuador@weg.net

FRANCE

Saint-Quentin-Fallavier - Isère
Phone: +33 4 74991135
info-fr@weg.net

GERMANY

Türnich - Kerpen
Phone: +49 2237 92910
info-de@weg.net

Balingen - Baden-Württemberg
Phone: +49 7433 90410
info@weg-antriebe.de

Homburg (Efze) - Hesse
Phone: +49 5681 99520
info@akh-antriebstechnik.de

GHANA

Accra
Phone: +233 30 2766490
ghana@zestweg.com

INDIA

Bangalore - Karnataka
Phone: +91 080 46437450
info-in@weg.net

Hosur - Tamil Nadu
Phone: +91 4344 301577
info-in@weg.net

ITALY

Cinisello Balsamo - Milano
Phone: +39 2 61293535
info-it@weg.net

JAPAN

Yokohama - Kanagawa
Phone: +81 45 5503030
info-jp@weg.net

MALAYSIA

Shah Alam - Selangor
Phone: +60 3 78591626
info@wattdrive.com.my

MEXICO

Huehuetoca - Mexico
Phone: +52 55 53214275
info-mx@weg.net

Tizayuca - Hidalgo
Phone: +52 77 97963790
info-mx@weg.net

NETHERLANDS

Oldenzaal - Overijssel
Phone: +31 541 571080
info-nl@weg.net

PERU

La Victoria - Lima
Phone: +51 1 2097600
info-pe@weg.net

PORTUGAL

Maia - Porto
Phone: +351 22 9477700
info-pt@weg.net

RUSSIA and CIS

Saint Petersburg
Phone: +7 812 363 2172
sales-wes@weg.net

SOUTH AFRICA

Johannesburg
Phone: +27 (0) 11 7236000
info@zestweg.com

Cape Town
Phone: +27 (0) 21 507 7200
gentsets@zestweg.com

Heidelberg
Phone: +27 (0) 16 349 2683/4/5
wta@zestweg.com

SPAIN

Coslada - Madrid
Phone: +34 91 6553008
info-es@weg.net

Valencia
Phone: +34 96 1379296
info@autrial.es

SINGAPORE

Singapore
Phone: +65 68589081
info-sg@weg.net

Singapore
Phone: +65 68622220
info-sg@weg.net

SCANDINAVIA

Mölnlycke - Sweden
Phone: +46 31 888000
info-se@weg.net

UK

Redditch - Worcestershire
Phone: +44 1527 513800
info-uk@weg.net

UNITED ARAB EMIRATES

Jebel Ali - Dubai
Phone: +971 4 8130800
info-ae@weg.net

USA

Duluth - Georgia
Phone: +1 678 2492000
info-us@weg.net

Bluffton - Indiana
Phone: +1 800 5798527
info-us@weg.net

Minneapolis - Minnesota
Phone: +1 612 3788000
info-us@weg.net

Washington - Missouri
Phone: +1 636-239-9300
wegwill@weg.net

VENEZUELA

Valencia - Carabobo
Phone: +58 241 8210582
info-ve@weg.net

For those countries where there is not a WEG own operation, find our local distributor at www.weg.net.



WEG Group - Motors Business Unit
Jaraguá do Sul - SC - Brazil
Phone: +55 47 3276 4000
motores@weg.net
www.weg.net

